



X4M300 Datasheet

Presence Sensor

XeThru Datasheet **by Novelda AS**

Rev. G - Preliminary - October 18, 2018

Summary

The XeThru X4M300 is an industrialized sensor that complies with worldwide regulations ready for product integration. Based on Novelda's proprietary, highly integrated X4 system-on-chip (SoC), the sensor provides highly sensitive and accurate measurement of a person's presence in a programmable detection zone, together with distance and movement information.



Table of Contents

List of Features	5
Order Information	6
XeThru X4M300 Presence Sensor	6
Supported Profiles	6
Sensor Operation	6
Power-up and Reset	6
First Power-Up	6
Configuration	7
Running Sensor Directly from Power-up or Reset	7
IO-pins	7
Firmware Versions	7
Bootloader	8
Fail Safe Mode	8
XeThru Presence Profile	9
Overview	9
User Settings	9
Set Detection Zone	9
Sensitivity	9
LED	10
Frequency Band	10
IO-pin Control	10
Noise Map Control	10
Use Stored Noise Map	11
Use Default Noise Map	11
Adaptive Noise Map	11
Default User Settings	11
Sensor Operation in Presence Profile	12
Detect Presence	12
Measure Presence Data	12
IO-pin Functionality	13
Detection Range	13
Detection Time	15
Firmware Algorithms	16
Default Noise Map	17
Stored Noise Map	17
Start-up Time	18
Baseband Data Output	18
Pulse-Doppler Processing and Range-Doppler Data Output	18
Certification Mode	19
Overview	19
Certification Modes	19
Firmware Versions	20
X4M300 Version 1.0.7	20



X4M300 Version 1.1.4	21
X4M300 Version 1.2.1	21
X4M300 Version 1.3.1	21
X4M300 Version 1.4.7	21
X4M300 Version 1.5.10	22
X4M300 Version 1.6.6	22
X4M300 Version 1.6.8	22
Future versions of X4M300	22
X4M300 HW Revisions	23
Identifying HW revision	23
X4M02 Revision 4	23
X4M02 Revision 5	23
X4M02 Revision 6	23
X4M02 Revision 10	24
Software Resources	24
XeThru Explorer	24
XeThru Module Connector	24
Module Communication Protocol Wrapper (MCP Wrapper)	24
X4M300 Firmware Binary	25
Mechanical Data	25
Electrical Specification	25
X4M300 Interface Options	26
16-pin XeThru Interface Connector	26
Pin Descriptions	26
USB Connector	27
Communication Modes	27
Power System	28
Schematics and Bill of Material	28
Module User Guide	28
Placing the Sensor Module	28
Connecting the X4M300 to a host system	29
Interfacing via USB	29
Interfacing via UART	29
Interfacing via USRT	29
Reset control of X4M300	30
Upgrading the Firmware Using the Bootloader	30
Regulatory Approval	30
CE / ETSI Approval	31
EU Declaration of Conformity	33
FCC Approval	34
X4M300 Block Diagram	34
Radar Functional Description	35
FCC Regulatory Notices	35
ISED Approval	36
Regulatory Information Canada	36
RF Exposure Safety	36
Labelling Requirements for the Host Device	37



Errata	37
Firmware Version 1.0.7	37
Firmware Version 1.1.4	37
Firmware Version 1.2.1	38
Firmware Version 1.3.1	38
Firmware Version 1.4.7	38
Firmware Version 1.5.10	38
Firmware Version 1.6.6	39
Firmware Version 1.6.8	39
Errata in X4M02 Revision 6 and lower	39
Support and Resources	39
Disclaimer	39



1 List of Features

- People detection up to 9.4 meters
 - Measures distance from sensor to person
 - Presence detection of people with no other movement than respiration
- Obstacle detection up to 9.4 meters
 - Reports distance to first static target
- Radar sensor
 - Baseband data output
 - Pulse-Doppler output
- Novelda Ultra Wide Band (UWB) Impulse Radar X4 system on a chip (SoC)
- Built-in TX and RX antennas
- Multiple interface options
 - Serial interface, UART and USRT
 - On-board USB interface
- On-board multi-color LED
- Certifications
 - FCC for USA
 - CE for Europe
 - ISED for Canada



X4M300 Presence Sensor



1.1 Order Information

Order Code	Item Description	MOQ	MPQ	Packaging
X4M300	X4M300 Presence Sensor FCC and CE/ETSI version	1	1	1 unit in anti-static bag
X4M300-TR100	X4M300 Presence Sensor FCC and CE/ETSI version	100	100	100 units in anti-static tray

MOQ: Minimum Order Quantity

MPQ: Minimum Package Quantity

2 XeThru X4M300 Presence Sensor

The X4M300 Presence Sensor contains a Profile that can detect and monitor people's movement and presence within the detection zone. The sensor module is ready for product integration.

X4M300 senses human presence by detecting all major and minor motions in a room such as a person walking and hand movements. Its extreme sensitivity enables it to detect presence up to a distance of 9.4 meters with great accuracy. It is also able to measure the distance between the device and the user, and is not susceptible to "dead spots" within the detection zone.

The X4M300 has the ability to see presence of a person with no other movements than his respiration motion. This unique ability enables implementation of products that does not lose track of a person's presence if he/she sits still for a longer time period. With the XeThru technology's ability to see through light materials it also enables products that detect a person's presence while sleeping in a bed with a blanket, duvet or clothes covering the person's body.

2.1 Supported Profiles

A Profile is defined as a specific configuration of the sensor for a specific use case. New Profiles might be included based on market demand.

The following Profiles are included in X4M300:

- Presence Profile (default)

Additional Profiles may be added in future firmware upgrades.

3 Sensor Operation

3.1 Power-up and Reset

3.1.1 First Power-Up

At first power-up of the sensor, the default Profile will be loaded and started with its default User Settings. Each Profile has a default message that the sensor will start sending over the serial communication link.



3.1.2 Configuration

Profiles and User Settings can be modified and loaded as described in the Module Connector documentation found on www.xethru.com.

User Settings vary between different Profiles and each Profile has its own default settings. See the Profile description chapters for details.

User Settings can only be changed when the Profile is not running. To change any setting, follow these steps:

1. Stop running Profile (if any Profile is running)
2. Load desired Profile (if not already loaded)
3. Send settings commands
 - a. User Settings such as Detection Zone, Sensitivity etc.
 - b. Output Control settings that determine which messages will be sent over the serial communication link on X4M300
4. Start running Profile

New settings will be programmed into the sensor when a Profile is started. If new settings are given to the sensor, but power is turned off or lost before a Profile is started, the new settings are lost, and the sensor will remember its old settings at the next power up.

Changing between some Profiles will require the sensor to reset its microcontroller (MCU) to take effect. In this case, when starting to run the new Profile, the sensor will give an error reply, take all changes into affect, and reset. The host should then wait for a couple of seconds to issue new commands to load and start running the Profile. The sensor will then reply OK and start the new Profile. Examples of Profiles that require the sensor to reset its microcontroller are Profiles using only internal MCU memory versus Profiles using external memory on the sensor.

Switching Profile will load the last used User Settings for the new Profile. If the new Profile has not been run earlier, default User Settings for that Profile are used.

3.1.3 Running Sensor Directly from Power-up or Reset

At power-up or reset, the sensor will start with its last used settings.

3.2 IO-pins

Various Profiles may have different uses of IO-pins. Do not connect IO-pins that are not in use. The sensor module will pull up these IO-pins internally. Future FW upgrades of the sensor and any existing or future pin compatible products may use these unused IO-pins for other functionality.

3.3 Firmware Versions

The datasheet may describe features not yet implemented in the current firmware version of the module. The datasheet chapter Firmware Versions explains what features are implemented in which firmware versions.



3.4 Bootloader

The module has a bootloader to allow field firmware upgrades. The bootloader is locked and cannot be reprogrammed, thus it can never be erased, altered or removed from the module over the serial protocol. The bootloader can be entered through the serial protocol, and it is also possible to force the module into bootloader mode using the pin header interface. See datasheet chapter Interface Options for details.

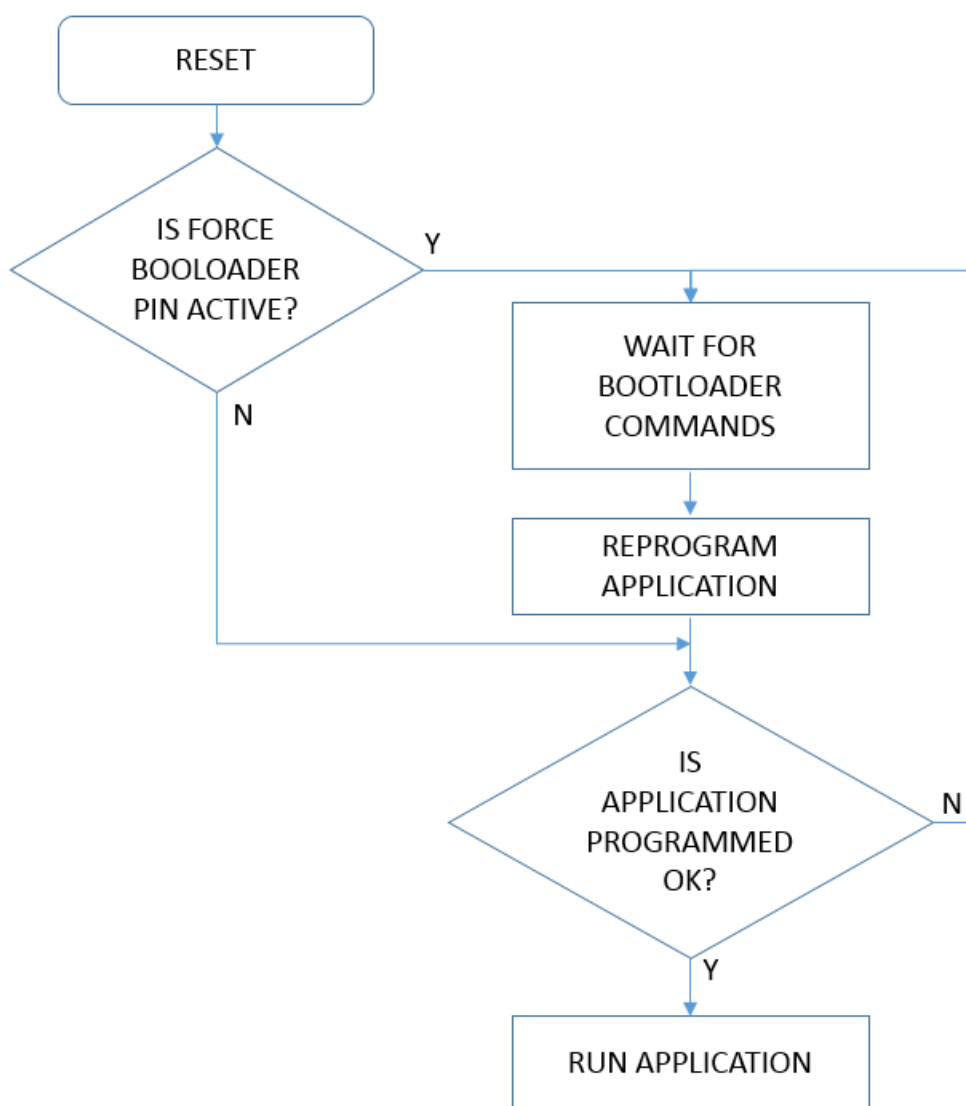

Bootloader flowchart

If a firmware upgrade fails (e.g. power loss) the host providing the firmware upgrade must reinitiate the entire firmware upgrade process. The previous version of the firmware may be lost, but the bootloader will still operate as described even after a failed firmware upgrade attempt.

If the Flash on the microcontroller is erased using an external programmer or debugger, the unit cannot be reprogrammed to default functionality by the user.

3.5 Fail Safe Mode

To contain possible issues that could unintentionally block communication and new firmware upgrades of X4M300, a Fail Safe Mode is implemented.



X4M300 will count the number of resets caused by issues in the firmware and enter Fail Safe Mode after ten such consecutive resets. In Fail Safe Mode, the LED of X4M300 will be white. In Fail Safe Mode, X4M300 will only respond to commands from the XEP interface, and a module reset or firmware upgrade command can be issued. A reset command or power toggle will make X4M300 resume normal operation.

4 XeThru Presence Profile

4.1 Overview

The XeThru Presence Profile detects human presence in a defined detection zone. The X4M300 must be still during use and can be installed in the ceiling, on the wall, or in a product that stands still on a table, bookshelf or similar.

4.2 User Settings

4.2.1 Set Detection Zone

The upper limit of the Detection Zone sets the maximum distance for presence detection, while the lower limit sets the minimum distance.

Detection Zone parameter limits	
Minimum lower range	0.40m
Maximum upper range	9.40m
Minimum size of detection zone	0.20m
Maximum size of detection zone	9.00m

Step size between possible range settings is 5.14 cm. The desired detection zone can be set with 1 cm resolution. The actual detection zone will be set at the closest value before/after the input lower/upper range. The actual lower and upper range used by the sensor can be read back after setting the detection zone.

Movements closer to the sensor than the Detection Zone may trigger detection because of indirect reflection paths. Movements beyond the end of the detection zone will never trigger detection.

4.2.2 Sensitivity

Sensitivity settings	
Minimum sensitivity	0
Maximum sensitivity	9
Sensitivity step size	1

Higher sensitivity setting gives better sensing of small targets. Lower sensitivity makes the sensor more robust against false detections.



4.2.3 LED

The module has 1 multi color RGB LED. The module LED can be configured between "Full" state indication, a "Simple" indication or "Off".

Full

Initializing: Green (0.2 sec) -> Orange (0.2 sec) -> Red (0.3 sec) -> Orange (0.2 sec) -> Green (0.2 sec) -> Off (0.3 sec)

Presence: Orange (0.5 sec) -> Green (0.5 sec)

No Presence: Red (0.3 sec) -> Off (4.7 sec)

No Profile running: Blue (0.2 sec) -> Off (4.7 sec)

Simple

Initializing: Green

Presence: Orange

No Presence: Red (0.3 sec) -> Off (4.7 sec)

No Profile running: Blue (0.2 sec) -> Off (4.7 sec)

Off

Always: Off

4.2.4 Frequency Band

Low

In the low frequency band, X4M300 will operate within the 6.0 - 8.5 GHz band.

High

In the high frequency band, X4M300 will operate within the 7.25 - 10.20 GHz band.

4.2.5 IO-pin Control

On

When IO-pin control is On, IO-pins will operate as described in the IO-pin functionality table below.

Off

When IO-pin control is Off, IO-pins will be inputs with internal pull-up and have no function.

4.2.6 Noise Map Control

See Firmware Algorithms section below for a description on how Noise Maps are used. There are three User Settings for Noise Map Control: Use Stored Noise Map, Use Default Noise Map, and Adaptive Noise Map. There are two Noise Maps used in all Respiration Profiles, one for the Slow Range-Doppler matrix and one for the Fast Range-Doppler Matrix. When User Settings for Noise Map Control describe functions to control Noise Map, this control is valid for both Noise Maps used in the signal processing algorithms. When creating a new Noise Map, the X4M300 sensor must be still and there must be no people within the Detection Zone.



4.2.7 Use Stored Noise Map

On

If a valid Stored Noise Map exists this will be used at reset or when the Profile is started.

If no valid Stored Noise Map exists and Use Default Noise Map is off, a new Noise Map will be created during Initialization state. The newly created Noise Map will be stored in the sensor when Initialization is done. A noise map created with a different Detection Zone is not valid.

If no valid Stored Noise Map exists and Use Default Noise Map is on, the Default Noise Map will be used at reset or when the Profile is started.

Off

If Use Default Noise Map is off, a new Noise Map will always be created at reset or when the Profile is started. Sensor will be in Initialization state during Noise Map creation. A previously Stored Noise Map in the sensor will be ignored, but not overwritten, when the Profile starts.

If Use Default Noise Map is on, the Default Noise Map will be used at reset or when the Profile is started.

4.2.8 Use Default Noise Map

On

If Use Store Noise Map is on and a valid Stored Noise Map exists, Default Noise Map will not be used.

If Use Stored Noise Map is on and no valid Stored Noise Map exists, the Default Noise Map will be used at reset or when the Profile is started.

If Use Stored Noise Map is off, the Default Noise Map will be used at reset or when the Profile is started.

Off

The Default Noise Map will not be used.

4.2.9 Adaptive Noise Map

On

Enables Noise Map adaptation. Noise Map will still not adapt in certain conditions as described in Firmware Algorithms section below.

Off

Disables Noise Map adaptation.

4.2.10 Default User Settings

Default User Settings are applicable when the Presence Profile is selected, but no User Settings are specified.



User Setting	Default value
Detection zone	0.4 - 9.4 m
Sensitivity	5
LED	Full
Frequency band	Low
Use Stored Noise Map	Off
Use Default Noise Map	Off
Adaptive Noise Map	On

4.3 Sensor Operation in Presence Profile

4.3.1 Detect Presence

There are four states in the Presence Profile:

- **No Presence:** No presence detected
- **Presence:** Presence detected
- **Initializing:** The sensor initializes after the Presence Profile is executed
- **Error:** The sensor is in an error state and requires a Profile and User Settings to be loaded

4.3.2 Measure Presence Data

When running, the following data is reported:

- **State**

When in No Presence or Presence states, the following data is measured:

- **Distance to static target:** Distance in meters to major static target closest to the sensor
- **MovementSlow:** Movements for the previous 20 seconds
- **MovementFast:** Movements for the previous 1 seconds

The movement metrics (MovementSlow and MovementFast) show the degree of movement as a relative number from 0 to 100 both for 5.14 cm intervals in the Detection Zone and for the entire Detection Zone. 0 means no Doppler cells above the detection threshold, while 100 means that all Doppler cells in the range interval are above the detection threshold.

When in Presence state, the following additional data is measured:

- **Distance to closest moving target:** Distance in meters to moving target closest to the sensor
- **Direction of closest moving target:** Direction (Toward, Away or Still) of moving target closest to the sensor

Moving target means any non-still target, including a stationary person with only respiration movement, who will be reported as a moving target with No direction.



All data is updated and available over serial communication interface once per second.

4.3.3 IO-pin Functionality

All units are shipped with IO-pin functionality off (inputs with pull-up).

When enabling IO-pins, the default functionality is:

Default IO-pin functions when enabled

IO-pin	Name	Direction	Functionality
IO1	PRESENCE	Output	Low: Presence state High: No Presence, Initializing and Error states
IO2	NO PRESENCE	Output	Low: No Presence state High: Presence, Initializing and Error states
IO3		Input	Not in use. Do not connect
IO4		Input	Not in use. Do not connect
IO5		Input	Not in use. Do not connect
IO6		Input	Not in use. Do not connect

e

Each IO-pin has the following Pin Setup options:

- Input or output
- Open drain or push-pull
- Active high or active low
- Pull-up enable or disable

Each IO-pin can have one of these Pin Features:

- Disable all IO-pins. Using this feature overrides Pin Setup. Disabling all IO-pins means all IO-pins are input with pull-up.
- According to default functionality shown above. Using this feature overrides Pin Setup. Default IO-pin functionality also specifies which pins are inputs and outputs.
- Passive. Set and get IO-pin level over communication interface
- Presence. Function as described in table above, but can be set to any pin

4.4 Detection Range

Detection range defines at what range and angle as seen from the sensor a person can be detected. The detection range varies with the size of the target person, the movement type of the target person and the angle between the sensor and the target person.

Detection range should not be confused with the user setting Detection Zone. Detection Zone defines at what range X4M300 is doing measurements. Detection range describes what can be detected inside the Detection Zone.

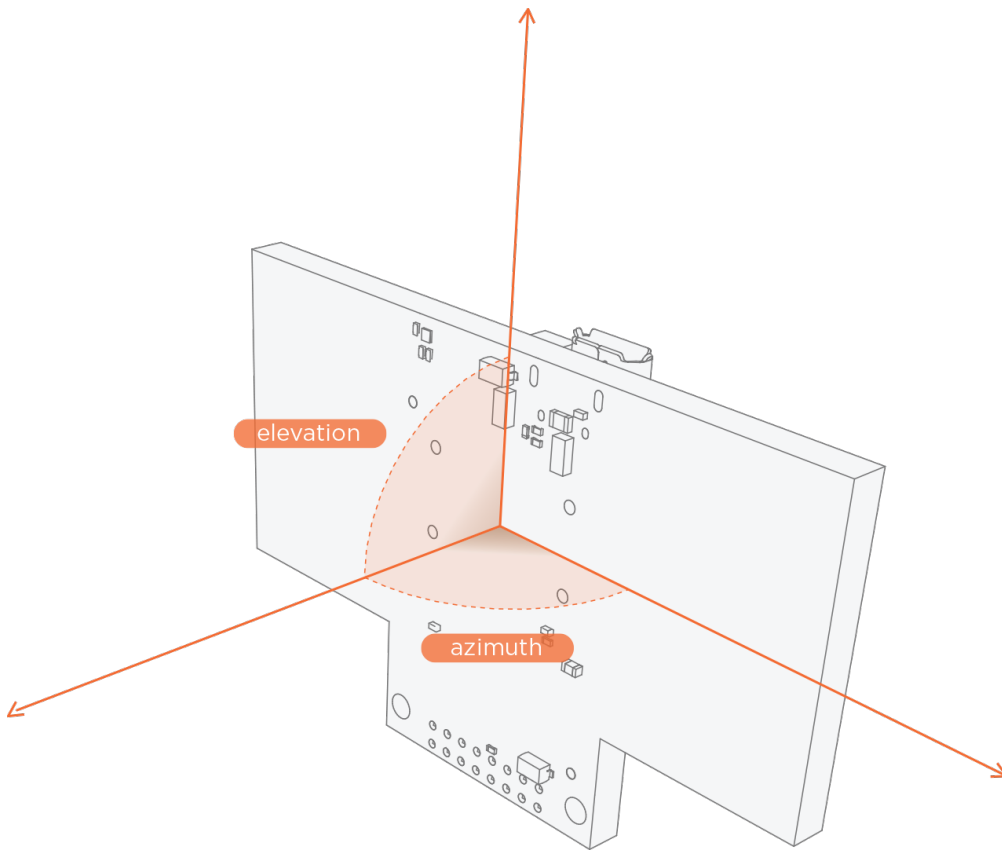
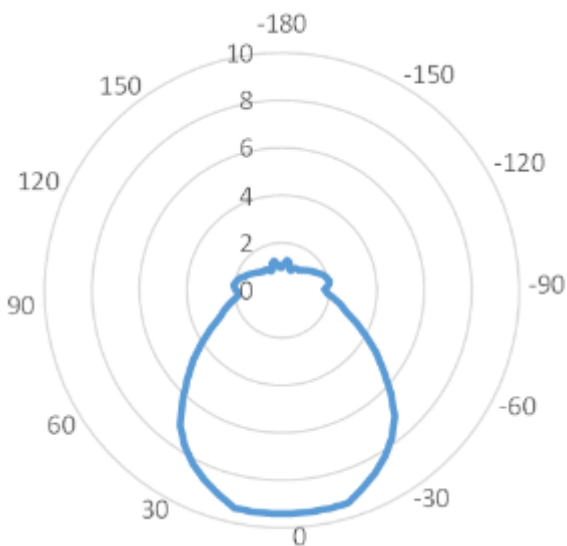

Illustration of 0° azimuth and 0° elevation

Detection range in meters for selected angles (preliminary values)

Azimuth / Elevation	0° / 0°	0° / 45°	45° / 0°	45° / 45°	0° / 90°	90° / 0
Respiration Motion	9.40 m	5.80 m	6.20 m	3.80 m	2.30 m	1.80 m
Minor Motion	9.40 m	9.40 m	9.40 m	9.40 m	6.50 m	5.10 m
Major Motion	9.40 m	9.40 m	9.40 m	9.40 m	7.00 m	5.40 m



Respiration Motion distance in meters shown as azimuth plot at 0° elevation

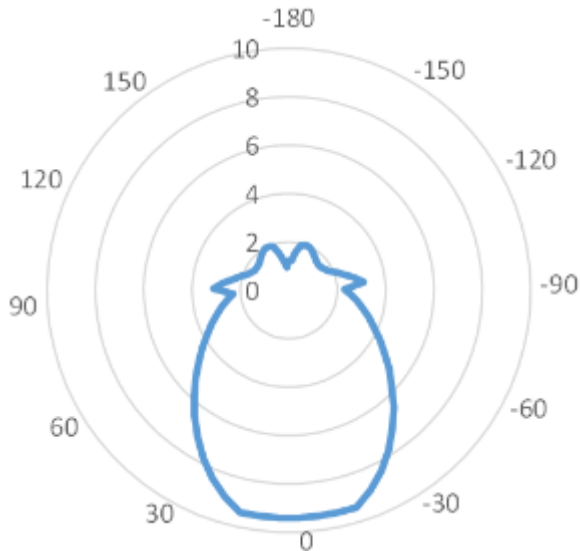

Respiration Motion distance in meters shown as elevation plot at 0° azimuth

Respiration Motion is defined as a standard person's respiration movement as seen from the side or back of the person.

Minor Motion is defined in NEMA WD 7 - 2011 as a standard person waving his arm at 90°/s. Standard arm size is 3in x 3in x 15in (7.6cm x 7.6cm x 38.6cm).

Major Motion is defined in NEMA WD 7 - 2011 as a standard person walking at a speed of 4 +/- 0.5 ft/s (1.22 +/- 0.3 m/s).

A standard person's respiration motion is defined as having a radar cross section of 0.001 m².

Detection range at additional azimuth and elevation angles will be available as an application note on www.xethru.com.

4.5 Detection Time

Typical detection time for this Profile is:

- From No Presence to Presence state: 1.5 - 3 seconds
- From Presence to No Presence state: 50 seconds



4.6 Firmware Algorithms

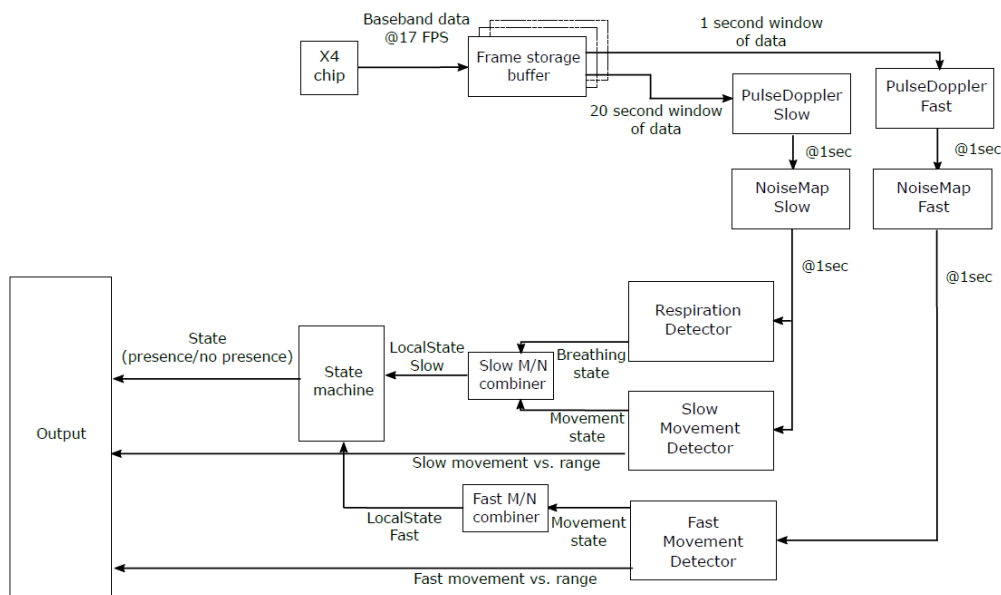

Presence Profile signal processing block diagram

All firmware algorithms for presence detection are running in the X4M300. The X4 UWB radar SoC is set up to provide 17 baseband data frames per second. The radar data frames are stored in a buffer. Two Range-Doppler matrices are running in parallel. The Slow Range-Doppler matrix is using the last 20 seconds of radar frames and the Fast Range-Doppler matrix is using the last 1 second of radar frames.

Both Range-Doppler matrices have individual Noise Maps to determine if a reflection at a certain distance and frequency is above a threshold. Creating and enabling a Noise Map will give different threshold values at different distances and frequencies and is recommended to achieve the best performance. If the Noise Maps are disabled a fixed threshold value will be used for all distances and frequencies, which in most cases will result in less sensitivity to small movements and higher risk of false detections.

The Noise Maps will adapt to changes in the environment unless Noise Map Adaptation is disabled. Noise Map adaptation works continuously and will over time remove presence detection of reflectors that are stationary. The Noise Map will not adapt if a still person with breathing frequency between 10 and 30 Respirations Per Minute (RPM) is detected.

The Fast Range-Doppler matrix with its Fast Movement Detector will detect presence quickly, typically when a person enters the Detection Zone. The Fast Movement Detector has two states, Movement or No Movement. The Fast M/N Combiner uses these states to determine the LocalStateFast. An M/N Combiner determines that M out of N detections need to be a certain value for the output to change.

Logic for Fast M/N Combiner

LocalStateFast	M/N
No Movement -> Movement	2/2
Movement -> No Movement	49/50

The Slow Range-Doppler matrix with its Slow Movement Detector will detect presence of stationary people. Typically when a person is in the Detection Zone with no other movements



than his respiration movement. The Slow Movement Detector has three states, Breathing, Movement and No Movement. The Slow M/N Combiner uses these states to determine the LocalStateSlow. An M/N Combiner determines that M out of N detections need to be a certain value for the output to change.

Logic for Slow M/N Combiner

LocalStateSlow	M/N
No Movement -> Movement	20/50
No Movement -> Breathing	20/50
Movement -> No Movement	31/50
Movement -> Breathing	7/7
Breathing -> No Movement	31/50
Breathing -> Movement	4/4

The State Machine determines the (global) State, which is No Presence when both LocalStateFast and LocalStateSlow is No Movement and Presence in all other local state combinations.

4.6.1 Default Noise Map

A Default Noise Map is provided with the sensor to achieve fast start-up even when no Noise Map has been created in the sensor earlier. The Default Noise Map represents a typical Noise Map for the sensor placed in an environment without reflections.

4.6.2 Stored Noise Map

The Active Noise Map, which is the Noise Map in use by the firmware algorithms, can be stored locally in the sensor as a Stored Noise Map. If a valid Stored Noise Map exists and the User Setting Use Stored Noise Map is on, the Stored Noise Map will be used when the Profile is started.

The Active Noise Map can become different than the Stored Noise Map due to Noise Map adaption. The Active Noise Map can be stored as the new Stored Noise Map, and the Stored Noise Map can be loaded as the Active Noise Map during operation of the sensor without stopping the Profile or disrupting operation of the sensor. The Stored Noise Map can be deleted without disrupting operation of the sensor. If the Noise Map is stored or deleted during sensor operation, X4M300 is not able to measure radar frames during the store or delete operation. The missing radar frames will be replaced with the next valid radar frame. For signal processing algorithms running in X4M300, these missing radar frames will have insignificant effect of the sensor performance.

To initialize a new Noise Map, delete the Stored Noise Map, and then stop and start the Profile with User Setting Use Store Noise Map on. A new Noise Map will then be created during Initialization, unless User Setting Use Default Noise Map is on, which dictates use of the Default Noise Map.

Only one Stored Noise Map can be saved in the sensor.

The Stored Noise Map can be read and stored by the host and a new Stored Noise Map can be loaded over the serial interface.



4.6.3 Start-up Time

The Range-Doppler matrices are filled with radar data during Initialization state. This takes 20 seconds for the Slow Range-Doppler matrix. Creating a Noise Map takes 100 seconds. Total start-up time is 120 seconds when a Noise Map needs to be created and 20 seconds if a Default Noise Map or Stored Noise Map is used.

4.7 Baseband Data Output

Baseband data is generated approximately 17 times per second and shows reflection at all distances in the Radar Frames used in 5.14 cm intervals.

The length and position of Radar Frames is controlled by the actual lower and upper range determined by the Detection Zone User Setting. The Radar Frame starts 5.14 cm before the actual lower range and ends 5.14 cm after the actual upper range.

Baseband data is available as an option on the communication port.

Baseband data outputs either amplitude and phase information of reflections, or the same data represented with I and Q values.

A Frame Counter is supplied with the Baseband Data. The Frame Counter increases by 1 for each radar frame that is output from the X4 UWB radar SoC. Stopping and starting a Profile does not reset the frame counter. Size of frame counter is 2^{32} . The frame counter wraps to 0 when it reaches the maximum. With 17 frames per second, the max value is reached in approximately 8 years. A reset of the X4 UWB radar SoC or a power toggle of the sensor module will reset the frame counter.

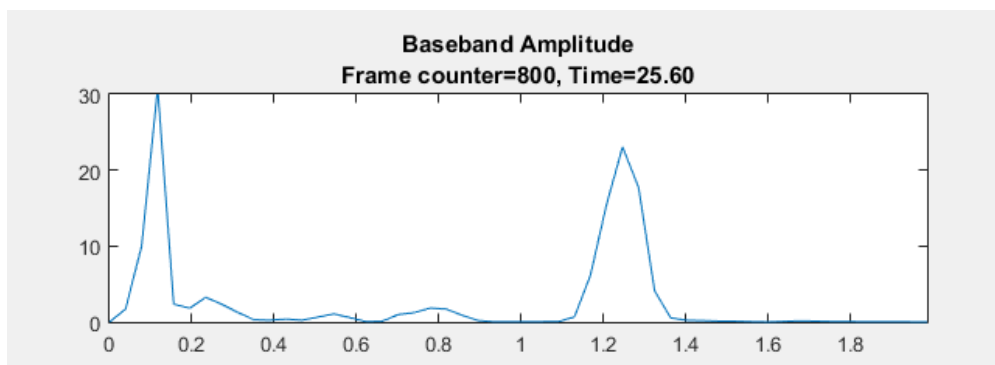

Example of baseband data output.

The example above shows the amplitude of reflections plotted for a 2 meter Radar Frame. This particular measurement shows two reflections; the first reflection is about 0.1 meter into the Radar Frame, which is the directly coupled energy from the TX to the RX antenna, and the second reflection is about 1.2 meter into the Radar Frame.

Refer to application notes on www.xethru.com for more detailed descriptions on how to use baseband data output.

4.8 Pulse-Doppler Processing and Range-Doppler Data Output

X4M300 uses Pulse-Doppler processing as described in more detail here: https://en.wikipedia.org/wiki/Pulse-Doppler_signal_processing.



Pulse-Doppler processing results in Range-Doppler data, which can be output from X4M300. The data is represented as Range-Doppler matrices that show all reflections at different distances and frequencies over the last time period as specified in the Firmware Algorithm section for each Profile. All reflections with Doppler frequency 0 (static reflectors) are removed before the Pulse-Doppler processing.



5 Certification Mode

5.1 Overview

X4M300 can be set in Certification Mode to test compliance with regulations.

5.2 Certification Modes

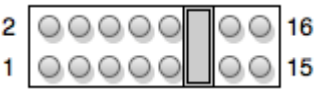
Various certification modes can be set either using the communication interface or by using jumpers or similar to short pins on the 16-pin XeThru Interface Connector.

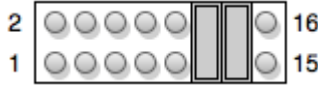
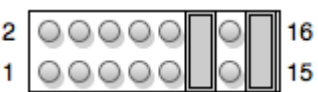
Certification Mode	Jumper Setting	Description
Tx Only		Enables continuous UWB transmission, with all other activities disabled. Meaning that only the digital circuitry needed for operating the UWB transmitter, and the UWB transmitter is enabled. This mode is used to demonstrate the isolated emissions from the UWB transmitter, and the emissions generated by the digital circuitry needed to enable UWB transmission. The UWB transmitter must be set to continuous worst case transmission, i.e. that a pulse is sent at every PRI interval for the given chip setting, to maximize the average energy emitted from the module. LED is off in this mode to minimize noise.
Tx Only Digital		Enables only the digital part used for continuous UWB transmitting, with all other activities disabled. The exact same settings as Tx only mode is used, but with the UWB transmitter disabled. This mode demonstrates radiated emissions from digital circuitry used to enable operation of the UWB transmitter. These emissions should comply with FCC 15.521, § 15.209. LED is off in this mode to minimize noise.
Stream Tx Off		Disables continuous UWB transmitting, while associated digital devices used to control additional functions or capabilities on module is operating. This mode is used to demonstrate emissions from unintentional radiators not needed for, or generated by, UWB transmission. LED is orange in this mode.
Stream		Normal operation of the module with both UWB transmitter and associated digital devices, used to control additional functions or capabilities on



Certification Mode	Jumper Setting	Description
		module, activated. This mode is used to demonstrate typical emissions from a module during normal operation. LED is orange in this mode.
Rx Fail Detection		<p>In normal operation, the FW monitors the sampler outputs to ensure acknowledgement of reception. If no such acknowledgement is received, the EUT will shut down the transmitter within 10 seconds.</p> <p>During certification test, this situation can be provoked / emulated by forcing the receiver to not provide an acknowledgement of reception. The procedure is as follows: 1. Power off the device. 2. Set the EUT in Stream mode by the appropriate jumpers (11/12 and 15/16). 3. Power up the device by connecting the USB cable. The EUT should now emulate normal operation. 4. Set RX Fail emulation jumper (13/14), this will emulate a missing acknowledgement within 3 seconds. 5. TX should now be shut down by the standard FW.</p> <p>Alternatively, all three jumpers may be set in step 2 and then power up and omit step 4. The EUT will start transmitting and within maximum 10 seconds shut down. LED is orange in this mode.</p>
End Certification Test		<p>Setting this jumper setting while the device is powered will return the module to normal operation after the execution of a power cycle. The module will then respond to the normal API over USB. Note that the EUT may be brought back to any other test mode by the appropriate jumper setting. LED is orange in this mode.</p>

6 Firmware Versions

The firmware version can be read over the serial interface. All firmware versions support upgrading to a different firmware version.

In addition to the firmware versions described in this section, additional firmware versions with potential error corrections and stability improvements should be expected.

6.1 X4M300 Version 1.0.7

First firmware version of X4M300 released to customers.

The following functions are supported:

- Presence / No Presence state
- Baseband data



- Distance to closest target
- MovementFast and MovementSlow data
- Noise Map is always initiated when the Presence Profile is started
- Noise Map always adapts
- Only the low frequency band can be used

HW rev.6 and above can not use this firmware version.

6.2 X4M300 Version 1.1.4

Features are same as for previous firmware version.

Improvements:

- Slow Pulse-Doppler matrix changed from 15 to 20 seconds, which improves sensitivity to detect people that are still.
- MovementSlow data shows movements for the previous 20 seconds. Previous FW version showed movements for the previous 15 seconds.
- Improved breathing detection, which leads to less adaption of noise map, which improves sensitivity to detect people that are still.
- Support for 2MB MCU (from X4M02 HW rev.6).
- Stability improvement. Previous FW version could reset unexpectedly.
- Changed enter bootloader command key to avoid unintentional downgrades of X4M02 with 2 MB MCU to FW version 1.0.7.
- Acknowledge stop command even when no Profile is loaded.

6.3 X4M300 Version 1.2.1

All functions from previous firmware version with exception of noise map that will not initiate at reset if this is not selected in User Settings.

Added features from previous version:

- Initialize Noise Map at Reset
- Store Noise Map to sensor
- Delete Stored Noise Map in sensor
- Pulse-Doppler data output

6.4 X4M300 Version 1.3.1

Features are same as for previous firmware version.

See errata section for bug fixes

6.5 X4M300 Version 1.4.7

Added features from previous version:

- GPIO functions
- USRT communication mode

See errata section for bug fixes



6.6 X4M300 Version 1.5.10

Added features from previous versions:

- Selection between low and high frequency band
- Get calls to protocol interface added (get_output_control, get_led_control, get_iopin_control, get_sensitivity)

6.7 X4M300 Version 1.6.6

The User Setting "Initialize Noise Map at Reset" has been renamed to "Use Stored Noise Map". Communication protocol is not affected by this change, thus any software controlling this User Setting for previous FW version will behave exactly the same with this and future FW versions.

Added features from previous version:

- Use Default Noise Map added
- Delete Noise Map protocol command added (delete_noisemap)

See errata section for bug fixes.

6.8 X4M300 Version 1.6.8

Added feature from previous version:

- NOPRESENCE IO-pin functionality added

6.9 Future versions of X4M300

The additional functions may be introduced in existing Profiles:

- Direction of closest target (Toward, Away or Still)
- Enable / disable Noise Map adaption (Previous versions always enable Noise Map adaption)
- Load a Stored Noise Map into active Noise Map in sensor
- Load and Store Noise Map to host
- Distance to first major static target
- Normalized Movement data that show the degree of movement and have adjustments for distance to give approximately the same value for the same size of movement at different distances

Some of these features may be introduced as a new Profile not yet documented in this datasheet.

- Detection list for all moving targets in detection zone
- Radar Cross Section for all moving targets in detection zone
- Faster response time from No Presence to Presence state



7 X4M300 HW Revisions

X4M300 uses the X4M02 hardware. This section describes all HW revisions of X4M02 that has been used in production, the difference between them and how to identify what HW revision your X4M300 is.

Some FW versions may require a specific HW revision. If applicable, this will be described in the FW version section of this datasheet.

7.1 Identifying HW revision

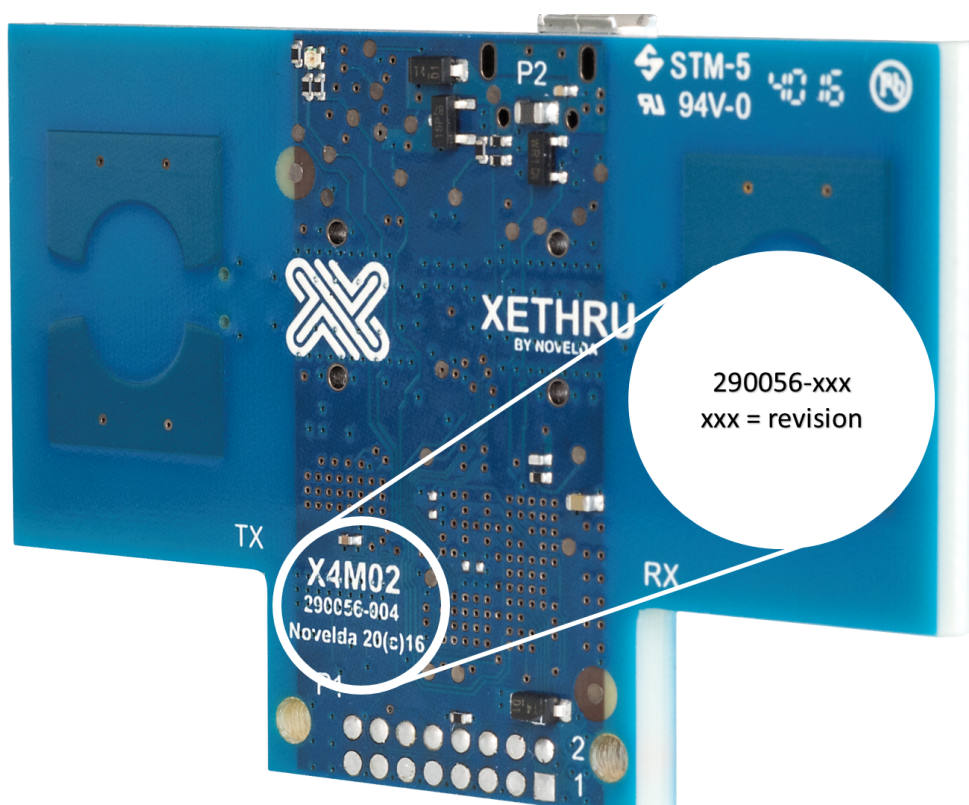

How to identify HW revision of X4M02

7.2 X4M02 Revision 4

Initial HW revision used for production of X4M300.

7.3 X4M02 Revision 5

- Added WiFi filter on Tx antenna.

Functionality is identical with previous HW revisions.

7.4 X4M02 Revision 6

Initial HW revision used for production of X4M200.



- MCU change from 1MB to 2MB version.

Functionality is identical with previous HW revisions.

7.5 X4M02 Revision 10

This HW revisions is required to meet the requirements for FCC and ETSI regulation.

- Added metal shield box on X4 UWB radar SoC.
- Replaced 12 MHz crystal with 12 MHz oscillator.
- Added components for EMI suppression.
- Added additional decoupling for MCU and SDRAM.
- Added filter on VDDPLLUSB domain.
- Improved MCU power delivery routing.
- Increased thickness of inner copper layers from 17 to 35 μm .

Functionality is identical with previous HW revisions.

8 Software Resources

8.1 XeThru Explorer

The XeThru Explorer application is a visual presentation of the protocol and data output from the sensor. It also allows for storing the measured data into a log file.

Firmware upgrades of X4M300 are deployed with new versions of XeThru Explorer.

XeThru Explorer can be downloaded from www.xethru.com.

8.2 XeThru Module Connector

The XeThru Module Connector is a software used to communicate with all XeThru radar sensor modules from a host computer through a serial interface. XeThru Module Connector makes a complete API of the modules available in host environments such as MATLAB, Python, C++ and C. This makes it easy to start streaming and analyzing radar data on multiple levels (raw radar data, baseband data, pulse doppler data, detection lists, respiration and presence) and directly to an environment ideally suited for development of new algorithms.

XeThru Module Connector includes a SW API that implements the serial protocol of X4M300.

XeThru Module Connector can be downloaded from www.xethru.com.

8.3 Module Communication Protocol Wrapper (MCP Wrapper)

Module Communication Protocol (MCP) is the lowest level communication protocol implementation for the XeThru modules, used on the module FW and XeThru host components, e. g. Module Connector. The MCP Wrapper goes one step further for embedded host implementation adding a wrapper with convenience methods around the MCP. Compared to Module Connector, which is a more feature rich component with logging and buffering capabilities, MCP Wrapper offers a similar interface with only the basic transport methods wrapped in a more easy-to-use interface.



Typical use for the MCP Wrapper is when implementing a host application communicating with a XeThru module on an embedded target that does not need or have the Module Connector available .

MCP Wrapper is implemented in C. Example code is available in C and C++.

MCP Wrapper can be downloaded from www.xethru.com.

8.4 X4M300 Firmware Binary

Firmware upgrades of X4M300 can be done by using Module Connector, MCP Wrapper or any other custom implementation of the serial protocol in a scenario where the modules are deployed. In this case, the module firmware file that is used during firmware upgrade is needed.

X4M300 firmware binary (Annapurna) can be downloaded from www.xethru.com.

9 Mechanical Data

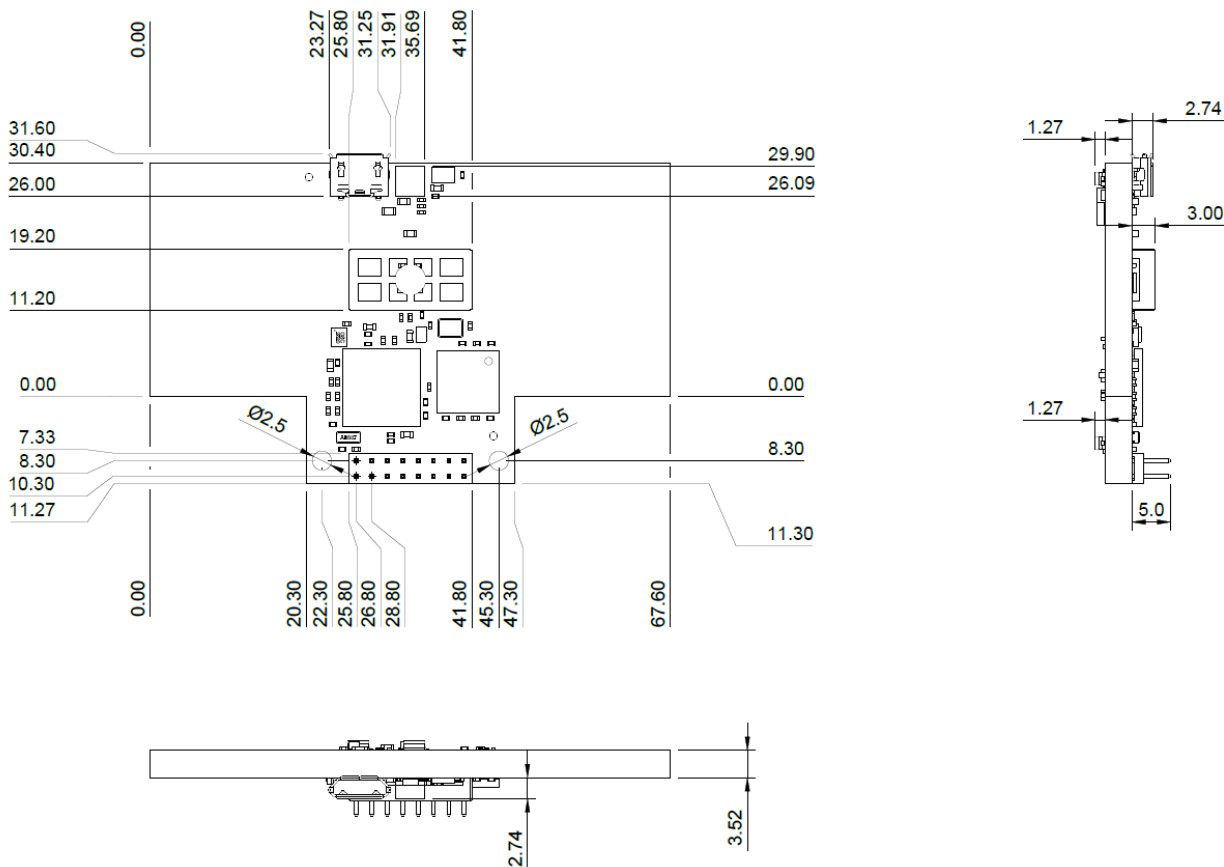

Mechanical drawing of the sensor module (in mm)

10 Electrical Specification

Parameter	Value	Comment
Supply Voltage VDD_EXT	3.3 - 5.5V	



Parameter	Value	Comment
Supply Voltage USB	4.5 - 5.5V	
IO-voltage range, nominal	-0.3 - 3.3V	
V _{IH} min	2.0V	Minimum input high threshold voltage
V _{IL} max	0.8V	Maximum input low threshold voltage
Typical power consumption	TBD mW	Expected around 600 mW
Operating Temperature range	0°C to +85°C	

11 X4M300 Interface Options

11.1 16-pin XeThru Interface Connector

The X4M300 has a 16-pin connector intended for interfacing a host board.

11.1.1 Pin Descriptions

Pin descriptions

Pin no	Description	Name	Type	Usage
1	Power, 3.3-5.5V	VDD_EXT	Power	Module power input
2	Power, GND	GND	Power	Module power input
3	USART RX / Force Bootloader	RX / BOOT	Input	USART receive / Holding pin 3 low during reset or power-up will force the unit into bootloader mode
4	USART TX	TX	Output	USART transmit
5	MODE SELECT 1 / USART SCK	MODESEL1	Input with pull-up	Mode select pin 1, ref table below for details / USART serial clock (USRT mode only)
6	MODE SELECT 2	MODESEL2	Input with pull-up	Mode select pin 2, ref table below for details
7	Reset	nRESET	Input with pull-up	Active low module MCU reset
8	No Connect	N.C	N/A	Leave unconnected



Pin no	Description	Name	Type	Usage
9	No Connect	N.C	N/A	Leave unconnected
10	No Connect	N.C	N/A	Leave unconnected
11	IO1	IO1	I/O	Functionality is Profile specific
12	IO2	IO2	I/O	Functionality is Profile specific
13	IO3	IO3	I/O	Functionality is Profile specific
14	IO4	IO4	I/O	Functionality is Profile specific
15	IO5	IO5	I/O	Functionality is Profile specific
16	IO6	IO6	I/O	Functionality is Profile specific

The connector is a 2x8 2.00mm pitch male pin header.

11.2 USB Connector

The X4M300 is fitted with a USB micro type B connector type supporting USB 2.0 High Speed.

11.3 Communication Modes

The sensor module will always use USB communication if USB power is present.

Additional communication modes can be selected at power-up or reset. The procedure is as follows seen from the host system outside the sensor:

1. Assert nRESET (set low for at least 1ms)
2. Set communication mode according to table below on pin 5 and 6.
3. Release nRESET (set high)
4. Hold communication mode level for minimum 2 seconds.
5. Set IO configuration of pins 3, 4, 5 and 6 to comply with the selected communication mode.
6. Selected communication is now activated on the sensor module

When USB is used this takes precedence over the table below. The use of USB is detected by the presence of power at the USB 5V power wire at startup. To change communication mode X4M300 need to be reset.

Mode	MODESEL1 (Pin 5)	MODESEL2 (Pin 6)	Comments
Reserved	Low	Low	Not supported
Reserved	Low	High	Not supported
USRT	High	Low	X4M300 is USRT slave
UART	High/Open (*)	High/Open (*)	Default UART settings are 115200 baud rate, 8 data bits, 1 stop bit, no parity



Mode	MODESEL1 (Pin 5)	MODESEL2 (Pin 6)	Comments
			This is the default mode. Enabled when pin 5 and pin 6 are left open.

(*) MODESEL1 and MODESEL2 has pull-up resistors and can be left open if a "High" is required.

Not supported modes should not be selected. Future firmware versions may use these modes.

11.4 Power System

There are 2 possible ways to power the sensor: Through pins 1 and 2 on the 16-pin interface connector or via USB. Both power sources may be connected at the same time. When powering via the USB connector this will always take precedence over the 16-pin connector.

12 Schematics and Bill of Material

Schematics and Bill of Material for X4M300 is available from www.xethru.com.

13 Module User Guide

13.1 Placing the Sensor Module

The sensor module should be protected from environmental surroundings such as moisture. Most firmware algorithms assume the sensor to be still with no movement or vibrations during operation.

When placing the sensor, pay attention to the following:

- Point the sensor in the direction of the object or zone to monitor
- Be aware of indirect reflections. An object 1 meter away may also give additional reflections via the floor, the ceiling or walls at longer distances
- Nearby metallic objects should be avoided, especially in the signal path to the sensor's observation area
- The sensor can be placed on static (non-moving) surfaces such as:
 - On a desk
 - On a wall
 - Behind a wall (*)
 - In the ceiling
 - Behind the ceiling (*)

Firmware algorithms in the sensor module are sensitive to vibrations. If vibrations occur, the sensor may report movement in an empty detection zone.

If a sensor casing is required, the material should be of a kind that does not attenuate the high frequency signals in the sensor's main direction. Recommended materials are ABS and other types of non-conductive plastics (*).

(*): Different materials will attenuate the signal. Application note regarding this topic is found at www.xethru.com.



13.2 Connecting the X4M300 to a host system

The X4M300 can be connected to a host system in several ways:

1. Via USB
2. Via the interface connector using the UART interface
3. Via the interface connector using the USRT interface. X4M300 will be a USRT slave.

Some Profiles have GPIO interface that can be enabled and operate as the only control interface for a sensor module. The GPIO interface is described in the Profile chapters of this datasheet.

Bootloader for firmware updates only supports USB and UART.

13.2.1 Interfacing via USB

When interfacing via USB this interface will take presence over other interfaces.

13.2.2 Interfacing via UART

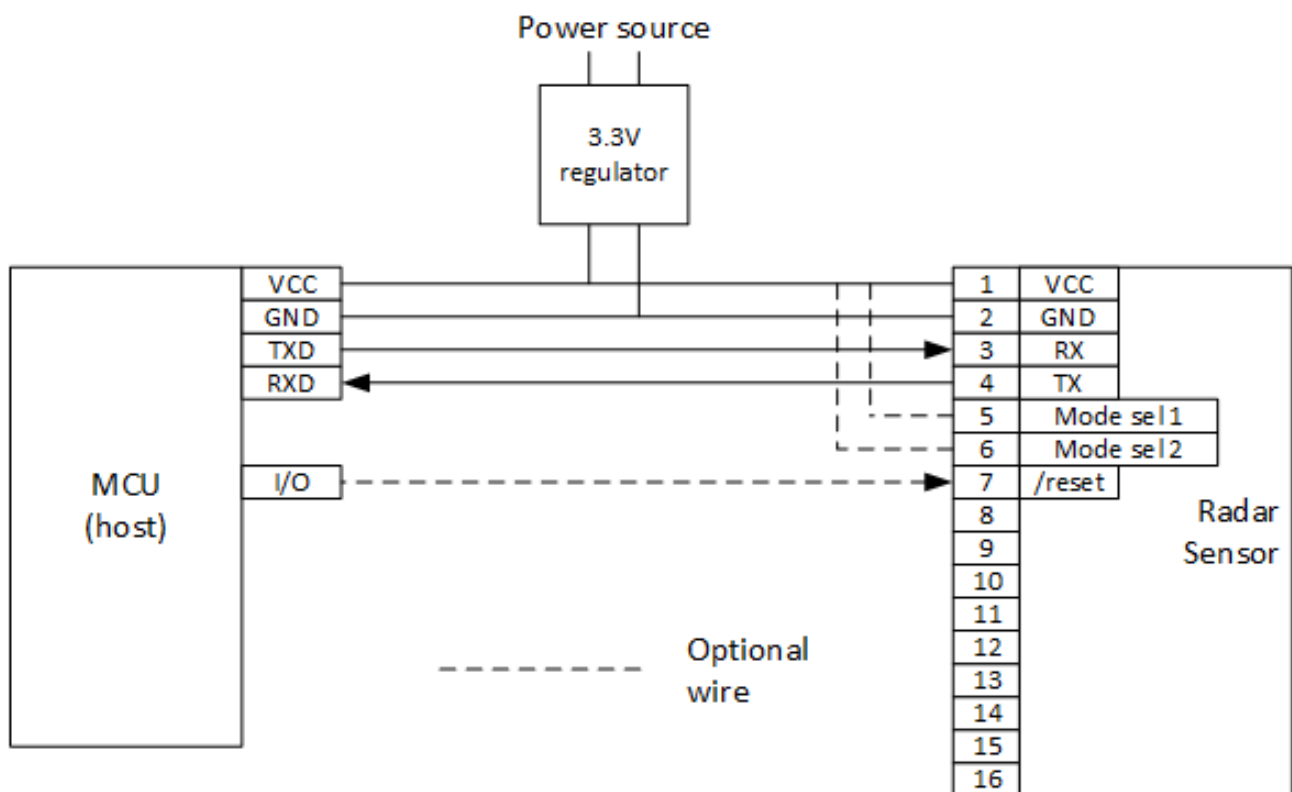

Simplified schematics of host MCU using UART mode

13.2.3 Interfacing via USRT

The USRT mode is using a clock line in addition to RX and TX lines.

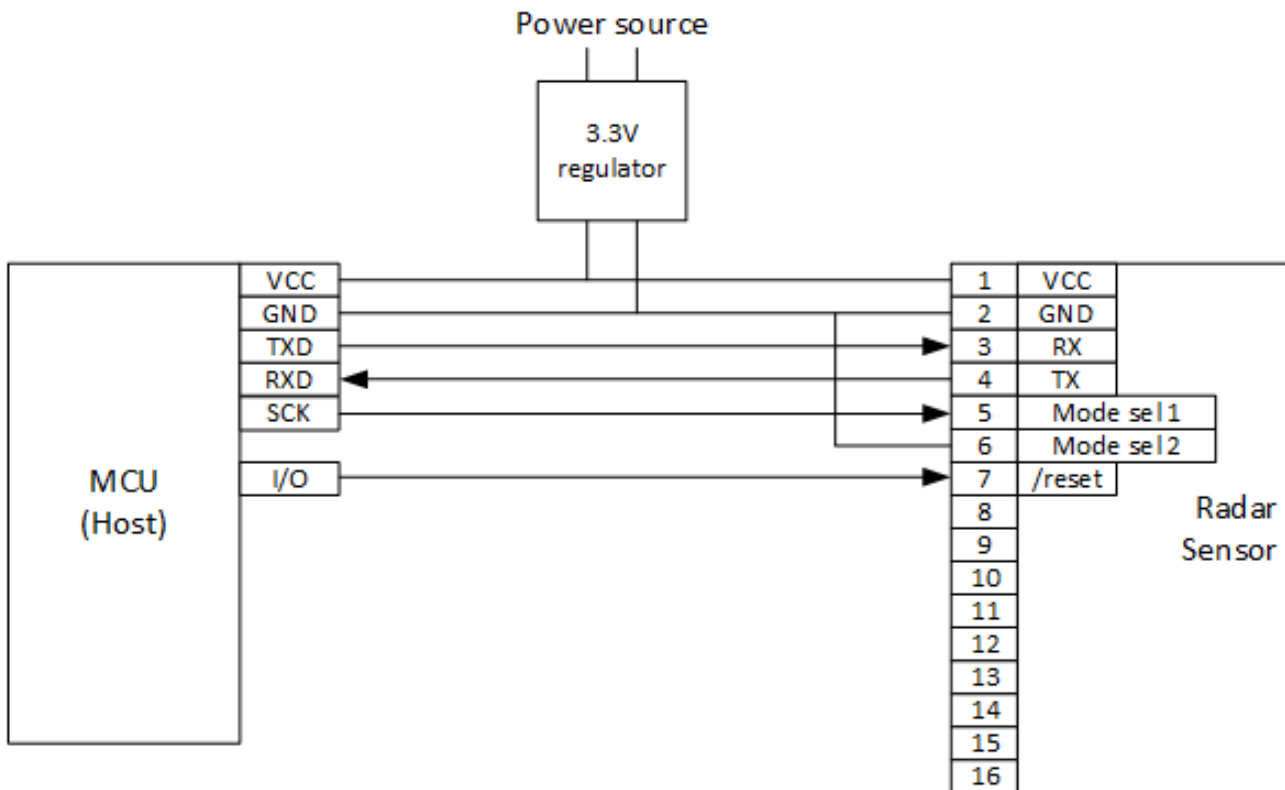

Simplified schematics of host MCU using USRT mode

13.2.4 Reset control of X4M300

Reset control from host is required for:

- Force bootloader function
- Exit from certain certification modes
- Selecting communication mode. UART is used if communication mode is not selected.

13.3 Upgrading the Firmware Using the Bootloader

The module's firmware may be updated over USB or UART.

LED will be purple during firmware upgrades.

14 Regulatory Approval

X4M300 is designed to meet UWB RF specifications of ETSI (Europe), FCC (USA) and ISED (Canada).

Some regulatory specifications also specify how the sensor is used. Users of X4M300 must check regulatory requirements for their own use case and determine whether the regulatory approvals obtained from Novelda are sufficient for their product.



14.1 CE / ETSI Approval

English:

Hereby, **Novelda AS** declares that the radio equipment type X4M300 is in compliance with Directive 2014/53/EU. The full text of the EU declaration of conformity is available below.

Suomi:

Novelda AS vakuuttaa, että radiolaitetyyppi X4M300 on direktiivin 2014/53/EU mukainen. EU-vaatimustenmukaisuusvakuutuksen koko teksti on saatavilla alla.

Nederlands:

Hierbij verklaar ik, **Novelda AS**, dat het type radioapparatuur X4M300 conform is met Richtlijn 2014/53/EU. De volledige tekst van de EU-conformiteitsverklaring is hieronder beschikbaar.

Français:

Le soussigné, **Novelda AS**, déclare que l'équipement radioélectrique du type X4M300 est conforme à la directive 2014/53/UE. Le texte intégral de la déclaration de conformité de l'UE est disponible ci-dessous.

Svenska:

Härmed försäkrar **Novelda AS** att denna typ av radioutrustning X4M300 överensstämmer med direktiv 2014/53/EU. Den fullständiga texten till EU-försäkran om överensstämmelse finns nedan.

Dansk:

Hermed erklærer **Novelda AS**, at radioudstyrstypen X4M300 er i overensstemmelse med direktiv 2014/53/EU. EU-overensstemmelseserklæringens fulde tekst kan findes nedenfor.

Deutsch:

Hiermit erklart **Novelda AS**, dass der Funkanlagentyp X4M300 der Richtlinie 2014/53/EU entspricht. Der vollständige Text der EU-Konformitätserklärung finden Sie weiter unten.

Ελληνικά:

Με την παρούσα ο/η **Novelda AS**, δηλώνει ότι ο ραδιοεξοπλισμός X4M300 πληροί την οδηγία 2014/53/ΕΕ. Το πλήρες κείμενο της δήλωσης συμμόρφωσης της ΕΕ είναι διαθέσιμο παρακάτω.

Italiano:

Il fabbricante, **Novelda AS**, dichiara che il tipo di apparecchiatura radio X4M300 è conforme alla direttiva 2014/53/UE. Il testo integrale della dichiarazione di conformità dell'UE è disponibile sotto.

Espanol:

Por la presente, **Novelda AS** declara que el tipo de equipo radioeléctrico X4M300 es conforme con la Directiva 2014/53/UE. El texto completo de la declaración de conformidad de la UE está disponible a continuación.

Portugues:

O(a) abaixo assinado(a) **Novelda AS** declara que o presente tipo de equipamento de radio X4M300 esta em conformidade com a Diretiva 2014/53/UE. O texto completo da declaração de conformidade da UE está disponível abaixo.

Čeština:

Tímto **Novelda AS** prohlašuje, že typ radiového zařízení X4M300 je v souladu se směrnicí 2014/53/EU. Úplné znění prohlášení o shodě EU je k dispozici níže.

**Eesti:**

Kaesolevaga deklareerib **Novelda AS**, et kaesolev raadioseadme tuup X4M300 vastab direktiivi 2014/53/EL nouetele. ELi vastavusdeklaratsiooni täielik tekst on allpool.

Magyar:

Novelda AS igazolja, hogy a X4M300 típusu radioberendezés megfelel a 2014/53/EU irányelvnek. Az EU-megfelelőségi nyilatkozat teljes szövege az alábbiakban található.

Latviešu valoda:

Ar šo **Novelda AS** deklarē, ka radioiekārta X4M300 atbilst Direktīvai 2014/53/ES. ES atbilstības deklarācijas pilns teksts ir pieejams zemāk.

Lietuvių kalba:

Aš, **Novelda AS**, patvirtinu, kad radijo įrenginių tipas X4M300 atitinka Direktyvą 2014/53/ES. Visas ES atitikties deklaracijos tekstas pateikiamas toliau.

Malti:

B'dan, **Novelda AS**, niddikjara li dan it-tip ta' tagħmir tar-radju X4M300 huwa konformi mad-Direttiva 2014/53/UE. It-test sħiħ tad-dikjarazzjoni ta 'konformità tal-UE huwa disponibbli hawn taħt.

Slovenčina:

Novelda AS týmto vyhlasuje, že rádiové zariadenie typu X4M300 je v súlade so smernicou 2014/53/EÚ. Úplné znenie vyhlásenia o zhode EÚ je k dispozícii nižšie.

Slovenščina:

Novelda AS potrjuje, da je tip radijske opreme X4M300 skladen z Direktivo 2014/53/EU. Celotno besedilo izjave EU o skladnosti je na voljo spodaj.

Romană:

Prin prezenta, **Novelda AS** declară că tipul de echipamente radio X4M300 este în conformitate cu Directiva 2014/53/UE. Textul integral al declarației UE de conformitate este disponibil mai jos.

български:

С настоящото **Novelda AS** декларира, че този тип радиосъоръжение X4M300 е в съответствие с Директива 2014/53/ЕС. Пълният текст на декларацията за съответствие на ЕС е на разположение по-долу.

Polski:

Novelda AS niniejszym oświadcza, że typ urządzenia radiowego X4M300 jest zgodny z dyrektywą 2014/53/UE. Pełny tekst deklaracji zgodności UE jest dostępny poniżej.

Norsk:

Novelda AS erklærer herved at radioutstyr type X4M300 er i samsvar med direktiv 2014/53/EU. Den fullstendige teksten i EU-samsvarserklæringen er tilgjengelig nedenfor.

Islenska:

Hér með **Novelda AS** lýsir yfir að tegund þráðlausan búnað X4M300 er í samræmi við tilskipun 2014/53/ESB. Fullkominn texti ESB samræmisýfirlýsing er að finna hér að neðan.

Hrvatski:

Novelda AS ovime izjavljuje da je radijska oprema tipa X4M300 u skladu s Direktivom 2014/53/EU. Cijeli tekst izjave o sukladnosti EU-a nalazi se u nastavku.

Türk:

Burada, **Novelda AS** radyo ekipmanı türünün X4M300 2014/53/EU direktiflerine uyumlu olduğunu beyan eder. AB uyumu beyanının tam metni aşağıda verilmektedir.



14.1.1 EU Declaration of Conformity



EU DECLARATION OF CONFORMITY

- 1 **XeThru X4M300** (product name)
- 2 Novelda AS, Garverivegen 2, NO-3850 Kviteseid, Norway (manufacturer, address)
- 3 This declaration of conformity is issued under the sole responsibility of the manufacturer
- 4 X4M300 Radar Sensor, HW version: 000164-010 (object of the declaration)
- 5 The object of the declaration described above is in conformity with the relevant Community harmonisation: European Directive 2014/53/EU (RED) and European Directive 2011/65/EU
- 6 The conformity with the essential requirements of the 2014/53/EU has been demonstrated against the following standards:

Standard reference	Article of Directive 2014/53/EU
EN 62479:2010 EN 60950-1:2006	3.1 (a): Health and Safety of the User
EN 301 489-1 (V2.1.1) EN 301 489-33 (V2.1.1)	3.1 (b): Electromagnetic Compatibility
EN 302 065-1 (V2.1.1)	3.2 : Effective use of spectrum allocated

In addition the requirements in **Directive (2011/65/EU)** on the restriction of use of certain hazardous substances in electrical and electronic equipment is satisfied by application of EN 50581:2012

Thus,  is placed on the product

- 7 The Technical Documentation (TD) relevant to the product described above and which supports this Declaration of Conformity, is held at: Novelda AS, Garverivegen 2, NO-3850 Kviteseid, Norway

Signed for and on behalf of Novelda AS

Kviteseid, 20.09.2017

Dag Arne Brænd, COO

Oslo
Novelda AS
Gjerdrumsvei 8
0484 Oslo
Norway

Kviteseid
Novelda AS
Garverivegen 2
3850 Kviteseid
Norway

Trondheim
Novelda AS
Rotvoll alle 2
7053 Trondheim
Norway



X4M300 EU Declaration of Conformity



14.2 FCC Approval

X4M300 has Modular FCC approval, which means it can be used in an end product without obtaining new authorization for the end product with regard to use of UWB radar.

The X4M300 module meets FCC Part 15 requirements for UWB transmission equipment intended for unlicensed indoor use or outdoor use when not permanently installed as specified in FCC Part 15.519, 15.521 and 15.209.

FCC ID: 2AD9QX4M02.

14.2.1 X4M300 Block Diagram

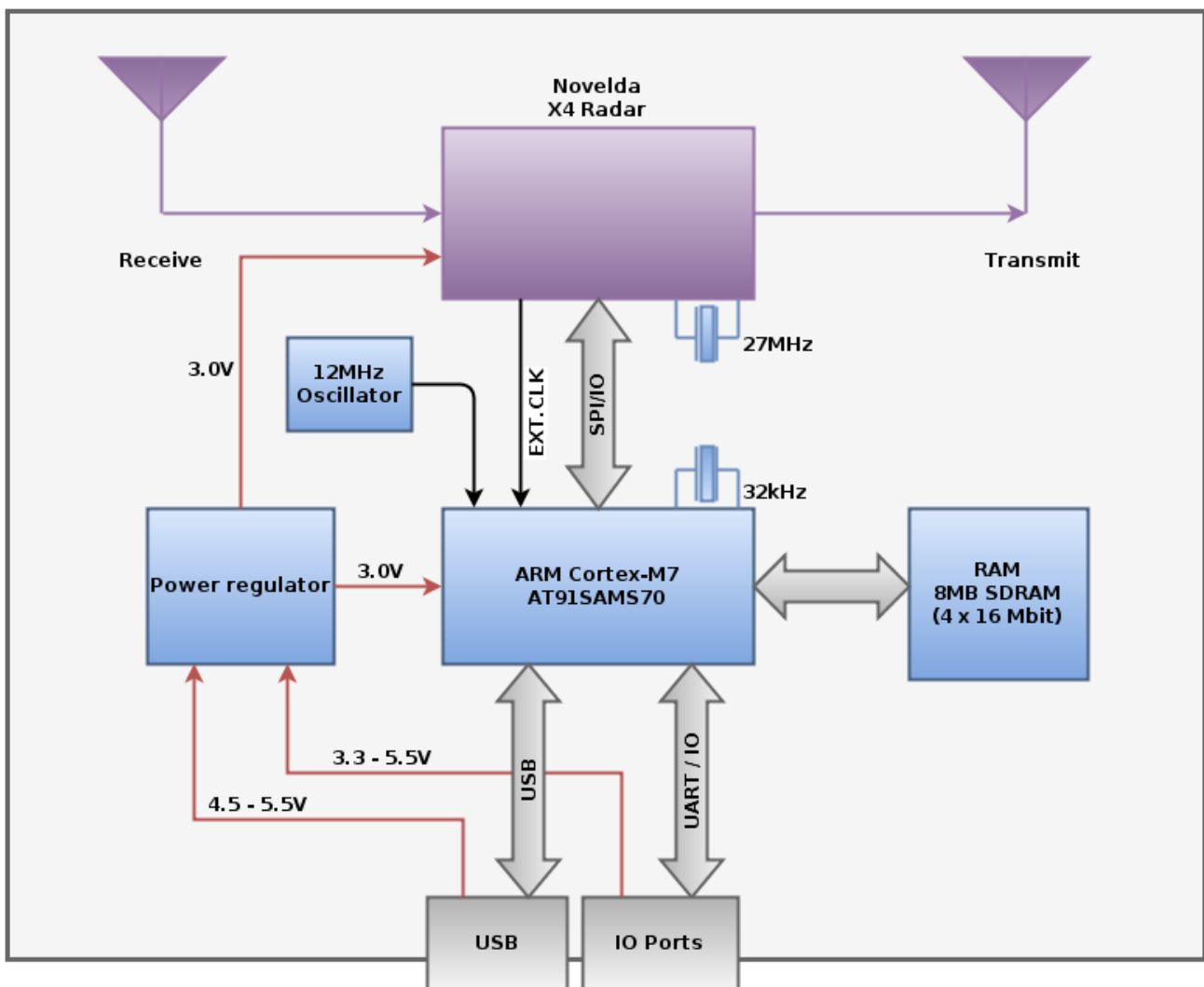

Module clock and power system

Clocks:

The systems clocks are derived from a 12 MHz crystal oscillator connected to the main microcontroller, and a 27 MHz oscillator connected to the Novelda X4 UWB impulse radar chip. The communication between the microcontroller and the X4 radar chip uses SPI protocol. The SPI communication clock is set up to run at 50 MHz.

Mean output power and frequency of the X4M300 depends on the Pulse Repetition Frequency (PRF), tx_power and Transmitter (TX) center frequency settings in the X4 radar chip. PRF must



be set to 15.1875 MHz, tx_power must be set to Medium (2), and the TX center frequency must be set to 7.29 GHz by the host system to be in compliance with FCC regulations. For further description of the X4 radar chip, please refer to the X4 datasheet.

Power:

The module is powered externally from either the USB port or an external power supply. If both power sources are connected, the USB takes precedence over the external power.

Antennas:

The antennas are embedded onto the PCB and cannot be changed by users. Please refer to the Antenna chapter in the X4M02 datasheet for details on the antennas.

14.2.2 Radar Functional Description

The module uses the Novelda X4 impulse radar chip. Please refer to the X4 datasheet for a detailed description.

14.2.3 FCC Regulatory Notices

Modification Statement

Novelda AS has not approved any changes or modifications to this device by the user. Any changes or modifications could void the user's authority to operate the equipment.

Interference Statement

This device complies with Part 15 of the FCC Rules. Operation is subject to the following two conditions: (1) this device may not cause interference, and (2) this device must accept any interference, including interference that may cause undesired operation of the device.

RF Exposure Safety

This equipment complies with FCC radiation exposure limits set forth for an uncontrolled environment. This transmitter must not be co-located or operating in conjunction with any other antenna or transmitter.

The X4M02 is a radio transmitter and receiver.

It is designed not to exceed the emission limits for exposure to radio frequency (RF) energy set by the Federal Communications Commission.

FCC Class B Digital Device Notice

This equipment has been tested and found to comply with the limits for a Class B digital device, pursuant to part 15 of the FCC Rules. These limits are designed to provide reasonable protection against harmful interference in a residential installation. This equipment generates, uses and can radiate radio frequency energy and, if not installed and used in accordance with the instructions, may cause harmful interference to radio communications. However, there is no guarantee that interference will not occur in a particular installation. If this equipment does cause harmful interference to radio or television reception, which can be determined by turning the equipment off and on, the user is encouraged to try to correct the interference by one or more of the following measures:

- Reorient or relocate the receiving antenna.
- Increase the separation between the equipment and receiver.



- Connect the equipment into an outlet on a circuit different from that to which the receiver is connected.
- Consult the dealer or an experienced radio/TV technician for help.

Labelling Requirements for the Host Device

The host device shall be properly labelled to identify the modules within the host device. The certification label of the module shall be clearly visible at all times when installed in the host device, otherwise the host device must be labelled to display the FCC ID of the module, preceded by the words "Contains transmitter module", or the word "Contains", or similar wording expressing the same meaning, as follows:

Contains FCC ID: 2AD9QX4M02

UWB devices may not be employed for the operation of toys. Operation on-board an aircraft, a ship or a satellite is prohibited.

14.3 ISED Approval

X4M300 is approved by Innovation, Science and Economic Development Canada (ISED), previously known as Industry Canada.

Certification Number: 22782-X4M02

14.3.1 Regulatory Information Canada

Changes or modifications not expressly approved by the party responsible for compliance could void the user's authority to operate the equipment.

Les changements ou modifications non expressément approuvés par la partie responsable de la conformité pourraient annuler l'autorisation de l'utilisateur d'utiliser l'équipement.

This device complies with Industry Canada's licence-exempt RSSs. Operation is subject to the following two conditions: (1) This device may not cause interference; and (2) This device must accept any interference, including interference that may cause undesired operation of the device.

Le présent appareil est conforme aux CNR d'Industrie Canada applicables aux appareils radio exempts de licence. L'exploitation est autorisée aux deux conditions suivantes : (1) l'appareil ne doit pas produire de brouillage, et (2) l'utilisateur de l'appareil doit accepter tout brouillage radioélectrique subi, même si le brouillage est susceptible d'en compromettre le fonctionnement.

14.3.2 RF Exposure Safety

The X4M02 is a radio transmitter and receiver.

It is designed not to exceed the emission limits for exposure to radio frequency (RF) energy set by the ISED.

Le X4M02 est un émetteur et un récepteur radio.

Il est conçu pour ne pas dépasser les limites d'émission pour l'exposition à l'énergie radiofréquence (RF) établie par l'ISDE.



14.3.3 Labelling Requirements for the Host Device

The host device shall be properly labelled to identify the modules within the host device. The certification label of the module shall be clearly visible at all times when installed in the host device, otherwise the host device must be labelled to display the IC of the module, preceded by the words "Contains transmitter module", or the word "Contains", or similar wording expressing the same meaning, as follows:

Contains IC: 22782-X4M02

Le'équipement hôte doit être correctement étiqueté pour identifier les modules dans l'équipement. L'étiquette de certification du module doit être clairement visible en tout temps lorsqu'il est installé dans l'hôte, l'équipement hôte doit être étiqueté pour afficher l'IC du module, précédé des mots "Contient le module émetteur", ou le mot "Contient", ou un libellé similaire exprimant la même signification, comme suit:

Contains IC: 22782-X4M02

CAN ICES-3 (B)/NMB-3(B)

15 Errata

15.1 Firmware Version 1.0.7

- X4M300 can unexpectedly reset.
- Memory leak in firmware may cause X4M300 to enter Fail Safe Mode.
 - Workaround: Toggle power or send a module reset command.
- Any reset, including intentional reset commands from a host, will cause the reset counter to increase. Fail Safe Mode may trigger after first reset caused by issues in the firmware if nine or more reset from any source has been experienced since last power-up.
 - Workaround: Leave Fail Safe Mode by toggling power or send a module reset command.
- Data messages coming from the sensor has sporadic data corruptions. For application messages like Sleep and PresenceSingle, the checksum will be invalid. For data messages using the NoEscape format, there is no checksum in use.
- The field *trx_dac_step_clog2* in the X4 register *trx_dac_step* is incorrectly set to value 1, instead of the correct value of 0. This causes 3dB reduction in the signal-to-noise ratio and can lead to lower sensitivity for practical applications

15.2 Firmware Version 1.1.4

- Memory leak in firmware may cause X4M300 to enter Fail Safe Mode.
 - Workaround: Toggle power or send a module reset command.
- Any reset, including intentional reset commands from a host, will cause the reset counter to increase. Fail Safe Mode may trigger after first reset caused by issues in the firmware if nine or more reset from any source has been experienced since last power-up.
 - Workaround: Leave Fail Safe Mode by toggling power or send a module reset command.



- Data messages coming from the sensor has sporadic data corruptions. For application messages like Sleep and PresenceSingle, the checksum will be invalid. For data messages using the NoEscape format, there is no checksum in use.
- The field *trx_dac_step_clog2* in the X4 register *trx_dac_step* is incorrectly set to value 1, instead of the correct value of 0. This causes 3dB reduction in the signal-to-noise ratio and can lead to lower sensitivity for practical applications

15.3 Firmware Version 1.2.1

- Memory leak in firmware may cause X4M300 to enter Fail Safe Mode.
 - Workaround: Toggle power or send a module reset command.
- Any reset, including intentional reset commands from a host, will cause the reset counter to increase. Fail Safe Mode may trigger after first reset caused by issues in the firmware if nine or more reset from any source has been experienced since last power-up.
 - Workaround: Leave Fail Safe Mode by toggling power or send a module reset command.
- Data messages coming from the sensor has sporadic data corruptions. For application messages like Sleep and PresenceSingle, the checksum will be invalid. For data messages using the NoEscape format, there is no checksum in use.
- The field *trx_dac_step_clog2* in the X4 register *trx_dac_step* is incorrectly set to value 1, instead of the correct value of 0. This causes 3dB reduction in the signal-to-noise ratio and can lead to lower sensitivity for practical applications.

15.4 Firmware Version 1.3.1

- Any reset, including intentional reset commands from a host, will cause the reset counter to increase. Fail Safe Mode may trigger after first reset caused by issues in the firmware if nine or more reset from any source has been experienced since last power-up.
 - Workaround: Leave Fail Safe Mode by toggling power or send a module reset command.
- Data messages coming from the sensor has sporadic data corruptions. For application messages like Sleep and PresenceSingle, the checksum will be invalid. For data messages using the NoEscape format, there is no checksum in use.
- The field *trx_dac_step_clog2* in the X4 register *trx_dac_step* is incorrectly set to value 1, instead of the correct value of 0. This causes 3dB reduction in the signal-to-noise ratio and can lead to lower sensitivity for practical applications.

15.5 Firmware Version 1.4.7

- When using UART or USRT communication, the sensor firmware will crash after 1024 received command bytes.
- Data messages coming from the sensor has sporadic data corruptions. For application messages like Sleep and PresenceSingle, the checksum will be invalid. For data messages using the NoEscape format, there is no checksum in use.
- The field *trx_dac_step_clog2* in the X4 register *trx_dac_step* is incorrectly set to value 1, instead of the correct value of 0. This causes 3dB reduction in the signal-to-noise ratio and can lead to lower sensitivity for practical applications.

15.6 Firmware Version 1.5.10

- When using UART or USRT communication, the sensor firmware will crash after 1024 received command bytes. Workaround: Upgrade to FW ver.1.6.6 or newer.



- Data messages coming from the sensor has sporadic data corruptions. For application messages like Sleep and PresenceSingle, the checksum will be invalid. For data messages using the NoEscape format, there is no checksum in use.
- The field *trx_dac_step_clog2* in the X4 register *trx_dac_step* is incorrectly set to value 1, instead of the correct value of 0. This causes 3dB reduction in the signal-to-noise ratio and can lead to lower sensitivity for practical applications.

15.7 Firmware Version 1.6.6

- The field *trx_dac_step_clog2* in the X4 register *trx_dac_step* is incorrectly set to value 1, instead of the correct value of 0. This causes 3dB reduction in the signal-to-noise ratio and can lead to lower sensitivity for practical applications .

15.8 Firmware Version 1.6.8

There are no known errata in this FW version.

15.9 Errata in X4M02 Revision 6 and lower

USB communication can be unstable. The issue is more frequently observed with Win7, and less observed with Win10, Raspberry Pi, macOS and Unix.

16 Support and Resources

Development support, resources, links to development partners and resellers can be found on Novelda's web site www.xethru.com.

17 Disclaimer

Novelda™, XeThru™ and others are registered trademarks or trademarks of Novelda AS. Other terms and product names may be trademarks of others.

DISCLAIMER: The information in this document is provided in connection with Novelda products. No license, express or implied, by estoppel or otherwise, to any intellectual property right is granted by this document or in connection with the sale of Novelda products. EXCEPT AS SET FORTH IN THE NOVELDA TERMS AND CONDITIONS OF SALES LOCATED ON THE NOVELDA WEBSITE, NOVELDA ASSUMES NO LIABILITY WHATSOEVER AND DISCLAIMS ANY EXPRESS, IMPLIED OR STATUTORY WARRANTY RELATING TO ITS PRODUCTS INCLUDING, BUT NOT LIMITED TO, THE IMPLIED WARRANTY OF MERCHANTABILITY, FITNESS FOR A PARTICULAR PURPOSE, OR NON-INFRINGEMENT. IN NO EVENT SHALL NOVELDA BE LIABLE FOR ANY DIRECT, INDIRECT, CONSEQUENTIAL, PUNITIVE, SPECIAL OR INCIDENTAL DAMAGES (INCLUDING, WITHOUT LIMITATION, DAMAGES FOR LOSS AND PROFITS, BUSINESS INTERRUPTION, OR LOSS OF INFORMATION) ARISING OUT OF THE USE OR INABILITY TO USE THIS DOCUMENT, EVEN IF NOVELDA HAS BEEN ADVISED OF THE POSSIBILITY OF SUCH DAMAGES. Novelda makes no representations or warranties with respect to the accuracy or completeness of the contents of this document and reserves the right to make changes to specifications and products descriptions at any time without notice. Novelda does not make any commitment to update the information contained herein. Unless specifically provided otherwise,



Novelda products are not suitable for, and shall not be used in, automotive applications. Novelda products are not intended, authorized, or warranted for use as components in applications intended to support or sustain life.

SAFETY-CRITICAL, MILITARY, AND AUTOMOTIVE APPLICATIONS DISCLAIMER: Novelda products are not designed for and will not be used in connection with any applications where the failure of such products would reasonably be expected to result in significant personal injury or death (“Safety-Critical Applications”) without a Novelda officer’s specific written consent. Safety-Critical Applications include, without limitation, life support devices and systems, equipment or systems for the operation of nuclear facilities and weapons systems. Novelda products are not designed nor intended for use in military or aerospace applications or environments unless specifically designated by Novelda as military-grade. Novelda products are not designed nor intended for use in automotive applications unless specifically designated by Novelda as automotive-grade.