



X4M02 Datasheet

X4 radar sensor module

XeThru Datasheet **by Novelda AS**

A Preliminary - December 11, 2017

Summary

X4M02 is an industrialized UWB radar module intended for custom application development



Table of Contents

List of Features	3
Order Information	3
Mechanical Data	4
Antenna	4
Connectors	5
16-pin XeThru Interface Connector	5
USB Connector	6
Electrical Specification	6
X4M02 HW Revisions	7
Identifying HW revision	7
X4M02 rev.4	7
X4M02 rev.5	7
X4M02 rev.6	8
X4M02 rev.10	8
Module User Guide	8
Placing the Sensor Module	8
Connecting the X4M02 to a Host System	9
Interfacing via USB	9
Interfacing via UART	9
Upgrading the Firmware Using the Bootloader	9
Regulatory Approval	9
CE / ETSI Approval	10
EU Declaration of Conformity	12
FCC Approval	13
X4M02 Block Diagram	13
Radar Functional Description	14
FCC Regulatory Notices	14
Industry Canada Approval	15
Regulatory Information Canada	15
RF exposure safety	15
Labelling Requirements for the Host Device	16
Schematics, Bill of Material and PCB Layout	16
Software Resources	16
XeThru Embedded Platform (XEP)	16
XeThru Module Connector	16
Support and Resources	17
Disclaimer	17



1 List of Features

- Radar sensor using X4 UWB radar SoC
- Built-in antennas
- Multiple interface options
 - USB
 - UART
 - SPI
 - I2C
- Single supply voltage, 3.3 - 5.5V
- On-board multi-color LED
- Certifications
 - FCC for USA
 - CE for Europe
 - IC for Canada

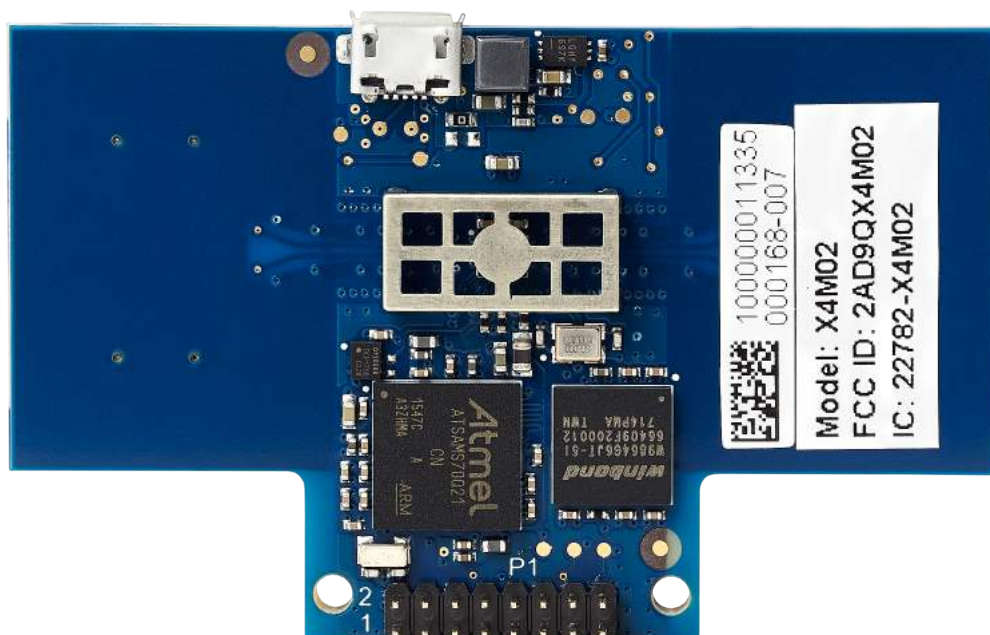

1.1 Order Information

Order Code	Item Description	MOQ	MPQ
X4M02	X4M02 X4 Radar Sensor	1	1

MOQ: Minimum Order Quantity

MPQ: Minimum Package Quantity



2 Mechanical Data

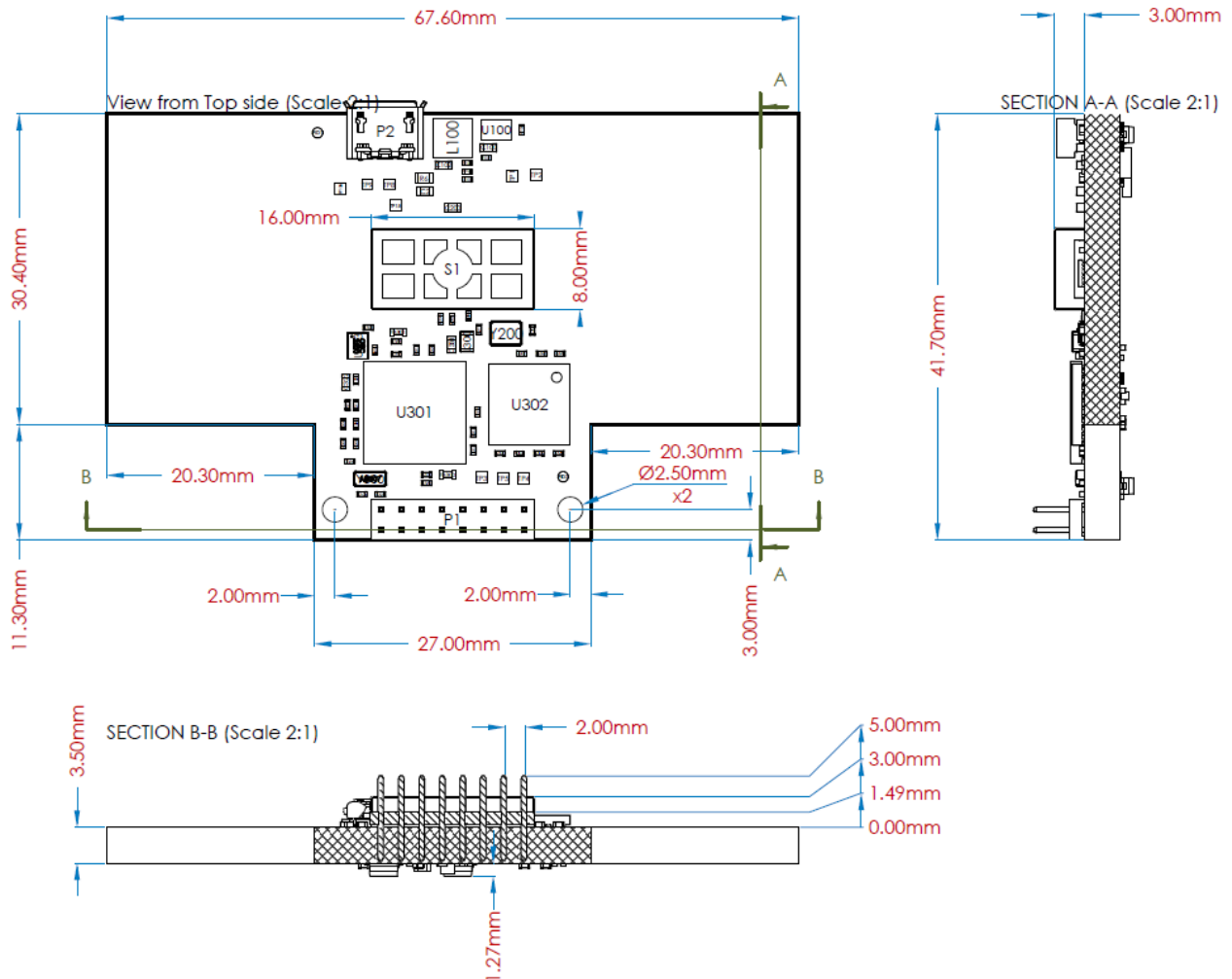

Mechanical drawing of the sensor module (in mm)

3 Antenna

X4M02 has two differential antennas optimized for the X4 UWB radar SoC, one for transmit and one for receive. The antennas are directional patch antennas with integrated WiFi filter (filtenna) optimized for frequencies between 6.0 and 8.5 GHz with a typical opening angle of 65° azimuth and elevation.

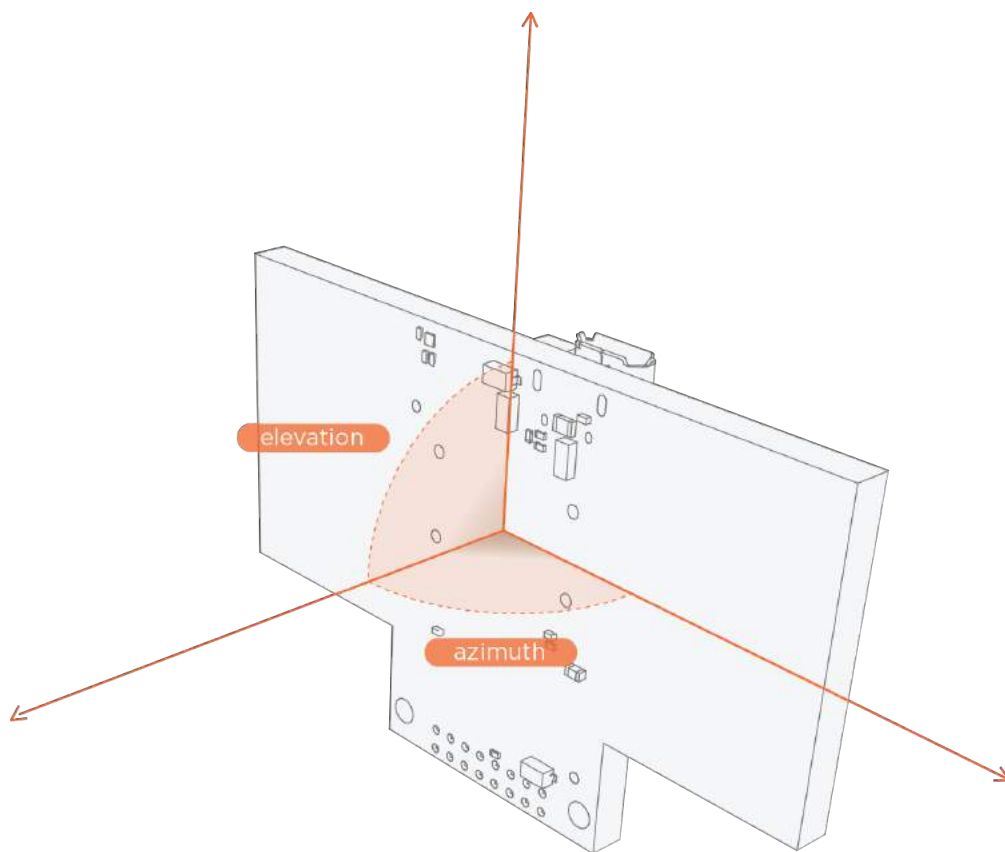
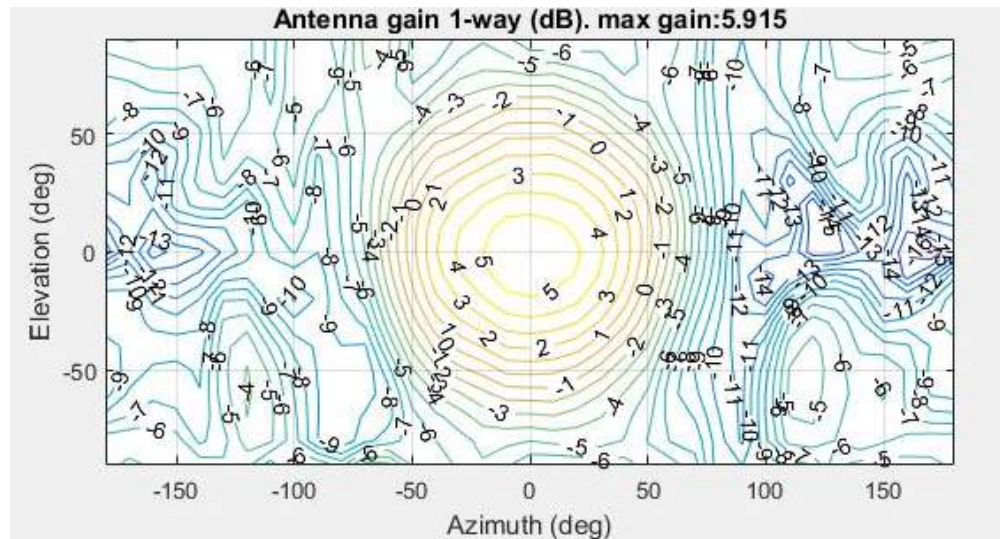

Illustration of 0° azimuth and 0° elevation



X4M02 antenna plot

4 Connectors

4.1 16-pin XeThru Interface Connector

The 16-pin header is compatible with other XeThru sensors such as X2M200 and can be used to power and communicate with X4M02. I/O voltage is 3.0V. Refer to the X4M02 schematics and the Atmel SAM S70 datasheet for additional details of operation.



Pin	Name	Type
1	VCC_EXT	Power, 3.3 - 5.5V
2	GND	Power
3	MOSI/RX	I/O
4	MISO/TX	I/O
5	SCLK	I/O
6	nSS	I/O
7	nRESET	Input with pull-up
8	IO7 /WAKEUP	I/O
9	IO8/SWCLK	I/O
10	IO9/SWDIO	I/O
11	IO1	I/O
12	IO2	I/O
13	IO3	I/O
14	IO4	I/O
15	IO5	I/O
16	IO6	I/O

4.2 USB Connector

USB micro type B connector supporting USB 2.0 High Speed. This connector can be used to power and communicate with X4M02.

5 Electrical Specification

Parameter	Value	Comment
Supply Voltage VDD_EXT	3.3 - 5.5V	
Supply Voltage USB	4.5 - 5.5V	
IO-voltage range, nominal	-0.3 - 3.3V	
V_{IH} min	2.0V	Minimum input high threshold voltage
V_{IL} max	0.8V	Maximum input low threshold voltage
Typical power consumption	TBD mW	Expected around 600 mW



Parameter	Value	Comment
Operating Temperature range	0°C to +85°C	

Power consumption of X4M02 is dependent of firmware running in the MCU.

6 X4M02 HW Revisions

X4M02 uses the X4M02 hardware. This section describes all HW revisions of X4M02 that has been used in production, the difference between them and how to identify what HW revision your X4M02 is.

Some FW versions may require a specific HW revision. If applicable, this will be described in the FW version section of this datasheet.

6.1 Identifying HW revision

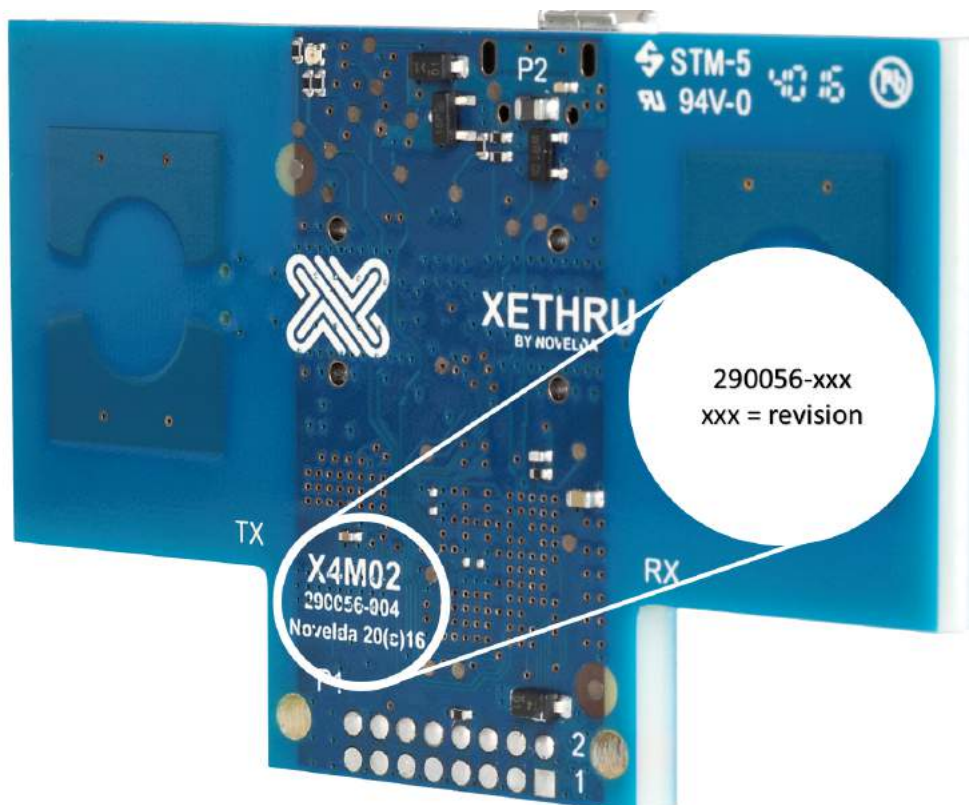

How to identify HW revision of X4M02

6.2 X4M02 rev.4

Initial HW revision used for production of X4M300.

6.3 X4M02 rev.5

- Added WiFi filter on Tx antenna.



Functionality is identical with previous HW revisions.

6.4 X4M02 rev.6

Initial HW revision used for production of X4M200.

- MCU change from 1MB to 2MB version.

Functionality is identical with previous HW revisions.

6.5 X4M02 rev.10

This HW revisions is required to meet the requirements for FCC and ETSI regulation.

- Added metal shield box on X4 UWB radar SoC.
- Replaced 12 MHz crystal with 12 MHz oscillator.
- Added components for EMI suppression.
- Added additional decoupling for MCU and SDRAM.
- Added filter on VDDPLLUSB domain.
- Improved MCU power delivery routing.
- Increased thickness of inner copper layers from 17 to 35 μm .

Functionality is identical with previous HW revisions.

7 Module User Guide

7.1 Placing the Sensor Module

The sensor module should be protected from environmental surroundings such as moisture. Most firmware algorithms assumes the sensor to be still with no movement or vibrations during operation.

When placing the sensor, pay attention to the following:

- Point the sensor in the direction of the object or zone to monitor
- Be aware of indirect reflections. An object 1 meter away may also give additional reflections via the floor, the ceiling or walls at longer distances
- Nearby metallic objects should be avoided, especially in the signal path to the sensor's observation area
- The sensor can be placed on static (non-moving) surfaces such as:
 - On a desk
 - On a wall
 - Behind a wall (*)
 - In the ceiling
 - Behind the ceiling (*)

Firmware algorithms in the sensor module are sensitive to vibrations. If vibrations occur, the sensor may report movement in an empty detection zone.

If a sensor casing is required, the material should be of a kind that does not attenuate the high frequency signals in the sensor's main direction. Recommended materials are ABS and other types of non-conductive plastics (*).



(*): Different materials will attenuate the signal. Application note regarding this topic is found at www.xethru.com.

7.2 Connecting the X4M02 to a Host System

The X4M02 can be connected to a host system in two ways:

1. Via USB
2. Via the interface connector using the UART interface

Some Profiles have GPIO interface that can be enabled and operate as the only control interface for a sensor module. The GPIO interface is described in the Profile chapters of this datasheet.

7.2.1 Interfacing via USB

When interfacing via USB, this interface will take precedence. X4M02 uses a standard Micro USB-B connector.

7.2.2 Interfacing via UART

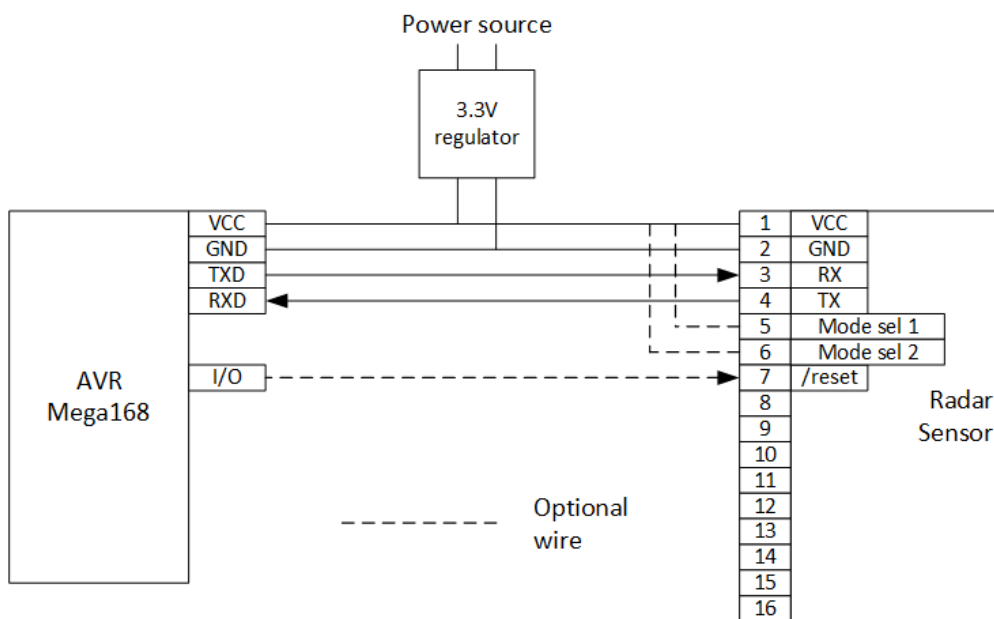

Atmel AVR (ATmega168) shown as example host

7.3 Upgrading the Firmware Using the Bootloader

The module's firmware may be update over USB or the serial port. XeThru Explorer can be used to update the module firmware.

LED will be purple during firmware upgrades.

8 Regulatory Approval

X4M02 is designed to meet UWB RF specifications of FCC and ETSI.



Some regulatory specifications also specify how the sensor is used. Users of X4M02 must check regulatory requirements for their own use case and determine whether the regulatory approvals obtained from Novelda are sufficient for their product.

8.1 CE / ETSI Approval

English:

Hereby, **Novelda AS** declares that the radio equipment type X4M02 is in compliance with Directive 2014/53/EU. The full text of the EU declaration of conformity is available below.

Suomi:

Novelda AS vakuuttaa, että radiolaitetyyppi X4M02 on direktiivin 2014/53/EU mukainen. EU-vaatimustenmukaisuusvakuutuksen koko teksti on saatavilla alla.

Nederlands:

Hierbij verklaar ik, **Novelda AS**, dat het type radioapparatuur X4M02 conform is met Richtlijn 2014/53/EU. De volledige tekst van de EU-conformiteitsverklaring is hieronder beschikbaar.

Français:

Le soussigné, **Novelda AS**, déclare que l'équipement radioélectrique du type X4M02 est conforme à la directive 2014/53/UE. Le texte intégral de la déclaration de conformité de l'UE est disponible ci-dessous.

Svenska:

Härmed försäkrar **Novelda AS** att denna typ av radioutrustning X4M02 överensstämmer med direktiv 2014/53/EU. Den fullständiga texten till EU-försäkran om överensstämmelse finns nedan.

Dansk:

Hermed erklærer **Novelda AS**, at radioudstyrstypen X4M02 er i overensstemmelse med direktiv 2014/53/EU. EU-overensstemmelseserklæringens fulde tekst kan findes nedenfor.

Deutsch:

Hiermit erklart **Novelda AS**, dass der Funkanlagentyp X4M02 der Richtlinie 2014/53/EU entspricht. Der vollständige Text der EU-Konformitätserklärung finden Sie weiter unten.

Ελληνικά:

Με την παρούσα ο/η **Novelda AS**, δηλώνει ότι ο ραδιοεξοπλισμός X4M02 πληροί την οδηγία 2014/53/ΕΕ. Το πλήρες κείμενο της δήλωσης συμμόρφωσης της ΕΕ είναι διαθέσιμο παρακάτω.

Italiano:

Il fabbricante, **Novelda AS**, dichiara che il tipo di apparecchiatura radio X4M02 è conforme alla direttiva 2014/53/UE. Il testo integrale della dichiarazione di conformità dell'UE è disponibile sotto.

Espanol:

Por la presente, **Novelda AS** declara que el tipo de equipo radioeléctrico X4M02 es conforme con la Directiva 2014/53/UE. El texto completo de la declaración de conformidad de la UE está disponible a continuación.

Portugues:

O(a) abaixo assinado(a) **Novelda AS** declara que o presente tipo de equipamento de radio X4M02 esta em conformidade com a Diretiva 2014/53/UE. O texto completo da declaração de conformidade da UE está disponível abaixo.

Čeština:

Tímto **Novelda AS** prohlašuje, že typ radiového zařízení X4M02 je v souladu se směrnicí 2014/53/EU. Úplné znění prohlášení o shodě EU je k dispozici níže.

**Eesti:**

Kaesolevaga deklareerib **Novelda AS**, et kaesolev raadioseadme tuup X4M02 vastab direktiivi 2014/53/EL nouetele. ELi vastavusdeklaratsiooni täielik tekst on allpool.

Magyar:

Novelda AS igazolja, hogy a X4M02 típusu radioberendezés megfelel a 2014/53/EU irányelvnek. Az EU-megfelelőségi nyilatkozat teljes szövege az alábbiakban található.

Latviešu valoda:

Ar šo **Novelda AS** deklarē, ka radioiekārta X4M02 atbilst Direktīvai 2014/53/ES. ES atbilstības deklarācijas pilns teksts ir pieejams zemāk.

Lietuvių kalba:

Aš, **Novelda AS**, patvirtinu, kad radijo įrenginių tipas X4M02 atitinka Direktyvą 2014/53/ES. Visas ES atitikties deklaracijos tekstas pateikiamas toliau.

Malti:

B'dan, **Novelda AS**, niddikjara li dan it-tip ta' tagħmir tar-radju X4M02 huwa konformi mad-Direttiva 2014/53/UE. It-test sħiħ tad-dikjarazzjoni ta 'konformità tal-UE huwa disponibbli hawn taħt.

Slovenčina:

Novelda AS týmto vyhlasuje, že rádiové zariadenie typu X4M02 je v súlade so smernicou 2014/53/EÚ. Úplné znenie vyhlásenia o zhode EÚ je k dispozícii nižšie.

Slovenščina:

Novelda AS potrjuje, da je tip radijske opreme X4M02 skladen z Direktivo 2014/53/EU. Celotno besedilo izjave EU o skladnosti je na voljo spodaj.

Romană:

Prin prezenta, **Novelda AS** declară că tipul de echipamente radio X4M02 este în conformitate cu Directiva 2014/53/UE. Textul integral al declarației UE de conformitate este disponibil mai jos.

български:

С настоящото **Novelda AS** декларира, че този тип радиосъоръжение X4M02 е в съответствие с Директива 2014/53/ЕС. Пълният текст на декларацията за съответствие на ЕС е на разположение по-долу.

Polski:

Novelda AS niniejszym oświadcza, że typ urządzenia radiowego X4M02 jest zgodny z dyrektywą 2014/53/UE. Pełny tekst deklaracji zgodności UE jest dostępny poniżej.

Norsk:

Novelda AS erklærer herved at radioutstyr type X4M02 er i samsvar med direktiv 2014/53/EU. Den fullstendige teksten i EU-samsvarserklæringen er tilgjengelig nedenfor.

Islenska:

Hér með **Novelda AS** lýsir yfir að tegund þráðlausan búnað X4M02 er í samræmi við tilskipun 2014/53/ESB. Fullkominn texti ESB samræmisýfirlýsing er að finna hér að neðan.

Hrvatski:

Novelda AS ovime izjavljuje da je radijska oprema tipa X4M02 u skladu s Direktivom 2014/53/EU. Cijeli tekst izjave o sukladnosti EU-a nalazi se u nastavku.

Türk:

Burada, **Novelda AS** radyo ekipmanı türünün X4M02 2014/53/EU direktiflerine uyumlu olduğunu beyan eder. AB uyumu beyanının tam metni aşağıda verilmektedir.



8.1.1 EU Declaration of Conformity



EU DECLARATION OF CONFORMITY

- 1 XeThru X4M02 (product name)
- 2 Novelda AS, Garverivegen 2, NO-3850 Kviteseid, Norway (manufacturer, address)
- 3 This declaration of conformity is issued under the sole responsibility of the manufacturer
- 4 X4M02 Radar Sensor, HW version: 000164-010 (object of the declaration)
- 5 The object of the declaration described above is in conformity with the relevant Community harmonisation: European Directive 2014/53/EU (RED) and European Directive 2011/65/EU
- 6 The conformity with the essential requirements of the 2014/53/EU has been demonstrated against the following standards:

Standard reference	Article of Directive 2014/53/EU
EN 62479:2010 EN 60950-1:2006	3.1 (a): Health and Safety of the User
EN 301 489-1 (V2.1.1) EN 301 489-33 (V2.1.1)	3.1 (b): Electromagnetic Compatibility
EN 302 065-1 (V2.1.1)	3.2 : Effective use of spectrum allocated

In addition the requirements in **Directive (2011/65/EU)** on the restriction of use of certain hazardous substances in electrical and electronic equipment is satisfied by application of EN 50581:2012

Thus,  is placed on the product

- 7 The Technical Documentation (TD) relevant to the product described above and which supports this Declaration of Conformity, is held at: Novelda AS, Garverivegen 2, NO-3850 Kviteseid, Norway

Signed for and on behalf of Novelda AS

Kviteseid, 20.09.2017

Dag Arne Brænd, COO

Oslo
Novelda AS
Gjerdrumsvei 8
0484 Oslo
Norway

Kviteseid
Novelda AS
Garverivegen 2
3850 Kviteseid
Norway

Trondheim
Novelda AS
Rotvoll alle 2
7053 Trondheim
Norway



X4M02 EU Declaration of Conformity



8.2 FCC Approval

X4M02 has Modular FCC approval, which means it can be used in an end product without obtaining new authorization for the end product with regard to use of UWB radar.

The X4M02 module meets FCC Part 15 requirements for UWB transmission equipment intended for unlicensed indoor use or outdoor use when not permanently installed as specified in FCC Part 15.519, 15.521 and 15.209.

FCC ID: 2AD9QX4M02.

8.2.1 X4M02 Block Diagram

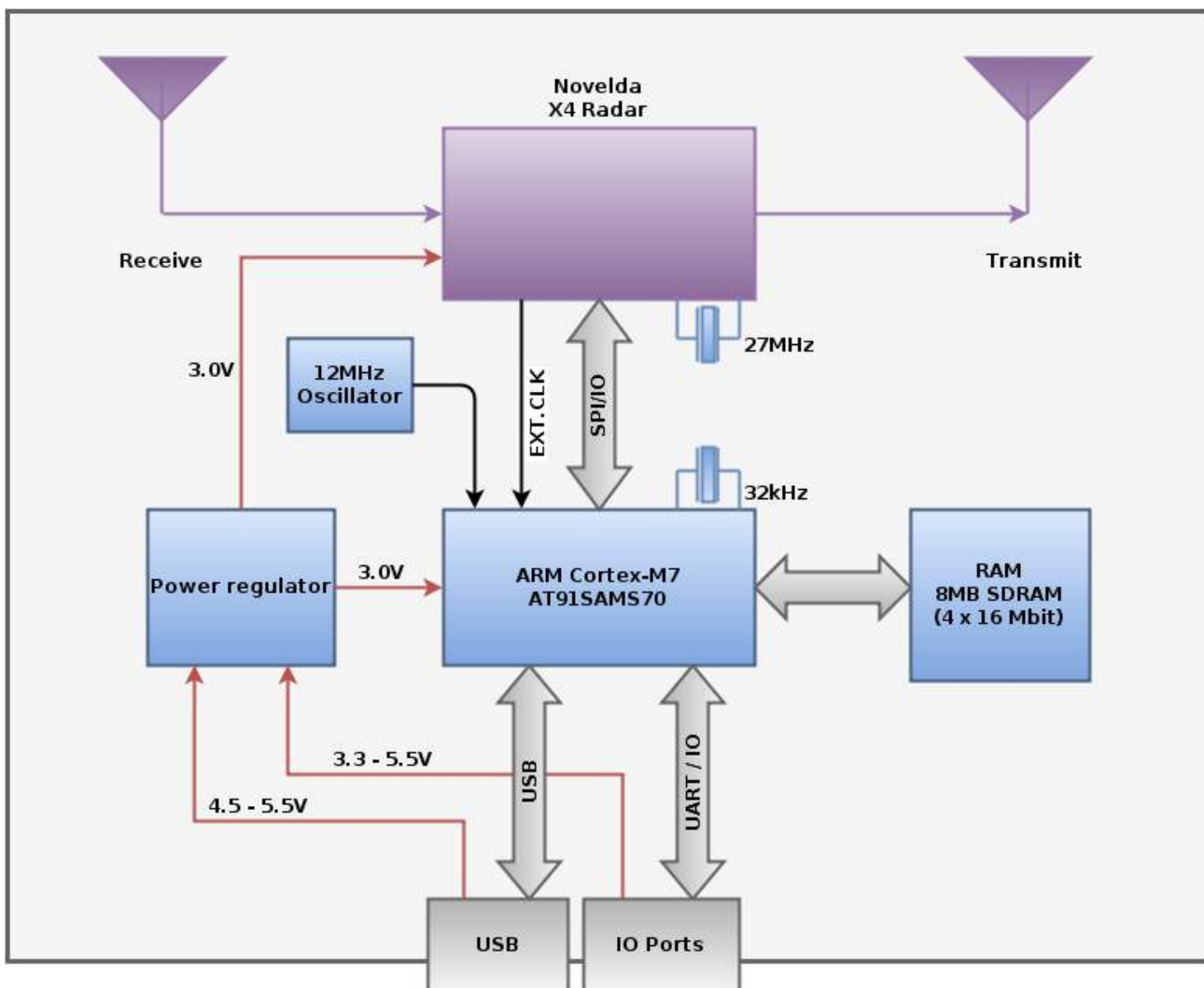

Module clock and power system

Clocks:

The systems clocks are derived from a 12 MHz crystal oscillator connected to the main microcontroller, and a 27 MHz oscillator connected to the Novelda X4 UWB impulse radar chip. The communication between the microcontroller and the X4 radar chip uses SPI protocol. The SPI communication clock is set up to run at 50 MHz.

Mean output power of X4M02 depends on the Pulse Repetition Frequency (PRF) and tx_power settings in the X4 radar chip. PRF is set to 15.875 MHz and tx_power is set to Medium (2) in



X4M02. Both the PRF and tx_power can be changed by the microcontroller but cannot be changed to comply with FCC regulations. For further description of the radar chip, please refer to the X4 datasheet.

Power:

The module is powered externally from either the USB port or an external power supply. If both power sources are connected, the USB takes precedence over the external power.

Antennas:

The antennas are embedded onto the PCB and cannot be changed by users. Please refer to the Antenna chapter in the X4M02 datasheet for details on the antennas.

8.2.2 Radar Functional Description

The module uses the Novelda X4 impulse radar chip. Please refer to the X4 datasheet for a detailed description.

8.2.3 FCC Regulatory Notices

Modification Statement

Novelda AS has not approved any changes or modifications to this device by the user. Any changes or modifications could void the user's authority to operate the equipment.

Interference Statement

This device complies with Part 15 of the FCC Rules. Operation is subject to the following two conditions: (1) this device may not cause interference, and (2) this device must accept any interference, including interference that may cause undesired operation of the device.

RF Exposure Safety

This equipment complies with FCC radiation exposure limits set forth for an uncontrolled environment. This transmitter must not be co-located or operating in conjunction with any other antenna or transmitter.

The X4M02 is a radio transmitter and receiver.

It is designed not to exceed the emission limits for exposure to radio frequency (RF) energy set by the Federal Communications Commission.

FCC Class B Digital Device Notice

This equipment has been tested and found to comply with the limits for a Class B digital device, pursuant to part 15 of the FCC Rules. These limits are designed to provide reasonable protection against harmful interference in a residential installation. This equipment generates, uses and can radiate radio frequency energy and, if not installed and used in accordance with the instructions, may cause harmful interference to radio communications. However, there is no guarantee that interference will not occur in a particular installation. If this equipment does cause harmful interference to radio or television reception, which can be determined by turning the equipment off and on, the user is encouraged to try to correct the interference by one or more of the following measures:

- Reorient or relocate the receiving antenna.
- Increase the separation between the equipment and receiver.



- Connect the equipment into an outlet on a circuit different from that to which the receiver is connected.
- Consult the dealer or an experienced radio/TV technician for help.

Labelling Requirements for the Host Device

The host device shall be properly labelled to identify the modules within the host device. The certification label of the module shall be clearly visible at all times when installed in the host device, otherwise the host device must be labelled to display the FCC ID of the module, preceded by the words "Contains transmitter module", or the word "Contains", or similar wording expressing the same meaning, as follows:

Contains FCC ID: 2AD9QX4M02

UWB devices may not be employed for the operation of toys. Operation on-board an aircraft, a ship or a satellite is prohibited.

8.3 Industry Canada Approval

X4M02 is approved by Industry Canada (IC)

IC Certification Number: 22782-X4M02

8.3.1 Regulatory Information Canada

Changes or modifications not expressly approved by the party responsible for compliance could void the user's authority to operate the equipment.

Les changements ou modifications non expressément approuvés par la partie responsable de la conformité pourraient annuler l'autorisation de l'utilisateur d'utiliser l'équipement.

This device complies with Industry Canada's licence-exempt RSSs. Operation is subject to the following two conditions: (1) This device may not cause interference; and (2) This device must accept any interference, including interference that may cause undesired operation of the device.

Le présent appareil est conforme aux CNR d'Industrie Canada applicables aux appareils radio exempts de licence. L'exploitation est autorisée aux deux conditions suivantes : (1) l'appareil ne doit pas produire de brouillage, et (2) l'utilisateur de l'appareil doit accepter tout brouillage radioélectrique subi, même si le brouillage est susceptible d'en compromettre le fonctionnement.

8.3.2 RF exposure safety

The X4M02 is a radio transmitter and receiver.

It is designed not to exceed the emission limits for exposure to radio frequency (RF) energy set by the ISED.

Le X4M02 est un émetteur et un récepteur radio.

Il est conçu pour ne pas dépasser les limites d'émission pour l'exposition à l'énergie radiofréquence (RF) établie par l'ISDE.



8.3.3 Labelling Requirements for the Host Device

The host device shall be properly labelled to identify the modules within the host device. The certification label of the module shall be clearly visible at all times when installed in the host device, otherwise the host device must be labelled to display the IC of the module, preceded by the words "Contains transmitter module", or the word "Contains", or similar wording expressing the same meaning, as follows:

Contains IC: 22782-X4M02

Le'équipement hôte doit être correctement étiqueté pour identifier les modules dans l'équipement. L'étiquette de certification du module doit être clairement visible en tout temps lorsqu'il est installé dans l'hôte, l'équipement hôte doit être étiqueté pour afficher l'IC du module, précédé des mots "Contient le module émetteur", ou le mot "Contient", ou un libellé similaire exprimant la même signification, comme suit:

Contains IC: 22782-X4M02

CAN ICES-3 (B)/NMB-3(B)

9 Schematics, Bill of Material and PCB Layout

Schematics, bill of material and PCB layout files for X4M02 can be downloaded from www.xethru.com.

10 Software Resources

10.1 XeThru Embedded Platform (XEP)

The XeThru Embedded Platform (XEP) is an open source code project that will run on the X4M03 and X4M02 radar development kits to support occupancy and respiration monitoring applications.

XEP comes as a ready-to-go Atmel Studio 7 project and implements all core functionalities for easy hardware module implementation.

XeThru Embedded Platform can be downloaded from www.xethru.com.

10.2 XeThru Module Connector

The XeThru Module Connector is a software used to communicate with all XeThru radar sensor modules from a host computer through a serial interface. XeThru Module Connector makes a complete API of the modules available in host environments such as MATLAB, Python, C++ and C. This makes it easy to start streaming and analyzing radar data on multiple levels (raw radar data, baseband data, pulse doppler data, detection lists, respiration and presence) and directly to an environment ideally suited for development of new algorithms.

XeThru Module Connector includes a SW API that implements the serial protocol of X4M02 .

XeThru Module Connector can be downloaded from www.xethru.com.



11 Support and Resources

Development support, resources, links to development partners and resellers can be found on Novelda's web site www.xethru.com.

12 Disclaimer

Novelda™, XeThru™ and others are registered trademarks or trademarks of Novelda AS. Other terms and product names may be trademarks of others.

DISCLAIMER: The information in this document is provided in connection with Novelda products. No license, express or implied, by estoppel or otherwise, to any intellectual property right is granted by this document or in connection with the sale of Novelda products. EXCEPT AS SET FORTH IN THE NOVELDA TERMS AND CONDITIONS OF SALES LOCATED ON THE NOVELDA WEBSITE, NOVELDA ASSUMES NO LIABILITY WHATSOEVER AND DISCLAIMS ANY EXPRESS, IMPLIED OR STATUTORY WARRANTY RELATING TO ITS PRODUCTS INCLUDING, BUT NOT LIMITED TO, THE IMPLIED WARRANTY OF MERCHANTABILITY, FITNESS FOR A PARTICULAR PURPOSE, OR NON-INFRINGEMENT. IN NO EVENT SHALL NOVELDA BE LIABLE FOR ANY DIRECT, INDIRECT, CONSEQUENTIAL, PUNITIVE, SPECIAL OR INCIDENTAL DAMAGES (INCLUDING, WITHOUT LIMITATION, DAMAGES FOR LOSS AND PROFITS, BUSINESS INTERRUPTION, OR LOSS OF INFORMATION) ARISING OUT OF THE USE OR INABILITY TO USE THIS DOCUMENT, EVEN IF NOVELDA HAS BEEN ADVISED OF THE POSSIBILITY OF SUCH DAMAGES. Novelda makes no representations or warranties with respect to the accuracy or completeness of the contents of this document and reserves the right to make changes to specifications and products descriptions at any time without notice. Novelda does not make any commitment to update the information contained herein. Unless specifically provided otherwise, Novelda products are not suitable for, and shall not be used in, automotive applications. Novelda products are not intended, authorized, or warranted for use as components in applications intended to support or sustain life.

SAFETY-CRITICAL, MILITARY, AND AUTOMOTIVE APPLICATIONS DISCLAIMER: Novelda products are not designed for and will not be used in connection with any applications where the failure of such products would reasonably be expected to result in significant personal injury or death ("Safety-Critical Applications") without an Novelda officer's specific written consent. Safety-Critical Applications include, without limitation, life support devices and systems, equipment or systems for the operation of nuclear facilities and weapons systems. Novelda products are not designed nor intended for use in military or aerospace applications or environments unless specifically designated by Novelda as military-grade. Novelda products are not designed nor intended for use in automotive applications unless specifically designated by Novelda as automotive-grade.