

NVA-R631 Radar Module

Impulse Radar Transceiver System

Key Features

- Single chip CMOS NVA6100 Impulse Radar
- 0.45 to 3.55 GHz transmit bandwidth (-10dB)
- Small form factor
- Cost efficient design
- 3.3V Digital Serial Peripheral Interface (SPI)
- SMA connectors for RF-in and RF-out
- On-board crystal oscillator
- On-board flash memory for storing calibration data
- Module power down function for low power duty cycled applications
- 4.5-6V operating voltage

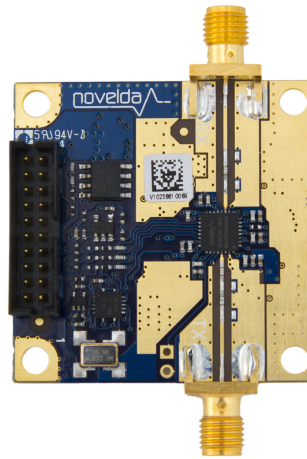

Product Description

The NVA-R631 is a ready-to-use impulse radar transceiver based on the NVA6100 single chip impulse radar from Novelda. The NVA-R631 delivers a complete front-end solution for remote sensing applications, and can be used as a plugin to existing systems, or as part of a pro-

totyping system based on the NVA-R631 Development Kit I/O module and software.

On-board voltage regulators and crystal oscillator ensures optimal performance and low noise.

Applications

- Medical diagnostics
- Vital sign monitoring
- Energy automation
- Through-wall imaging
- Tank gauging
- Materials evaluation
- Cable inspection
- Object tracking

Table of Contents

1. Specification	3
1.1. Electrical Specifications	3
1.2. Mechanical Specifications	3
2. Circuit Description	4
2.1. Connectivity	4
2.1.1. I/O Header pinout	4
2.1.2. CLK_OUT Connector	5
2.1.3. RX and TX Connectors	5
2.2. SPI Description	5
2.3. Clock Description	6
2.4. Power Supply Description	6
3. Contact Information	7
3.1. Novelda Corporate Headquarters	7
3.2. Novelda R&D Department	7
3.3. Ordering Information	7
3.4. Technical Support	7
4. Disclaimer	8

1. Specification

1.1. Electrical Specifications

Parameter	Value
Board supply voltage	4.5 - 6 V
Maximum input RF level	6 dBm
External clock frequency	up to 100 MHz
SPI clock frequency	up to 30 MHz
Logic input voltage level	3.3 V
Logic output voltage level	3.3 V

Table 1.1. General Operating Conditions.

1.2. Mechanical Specifications

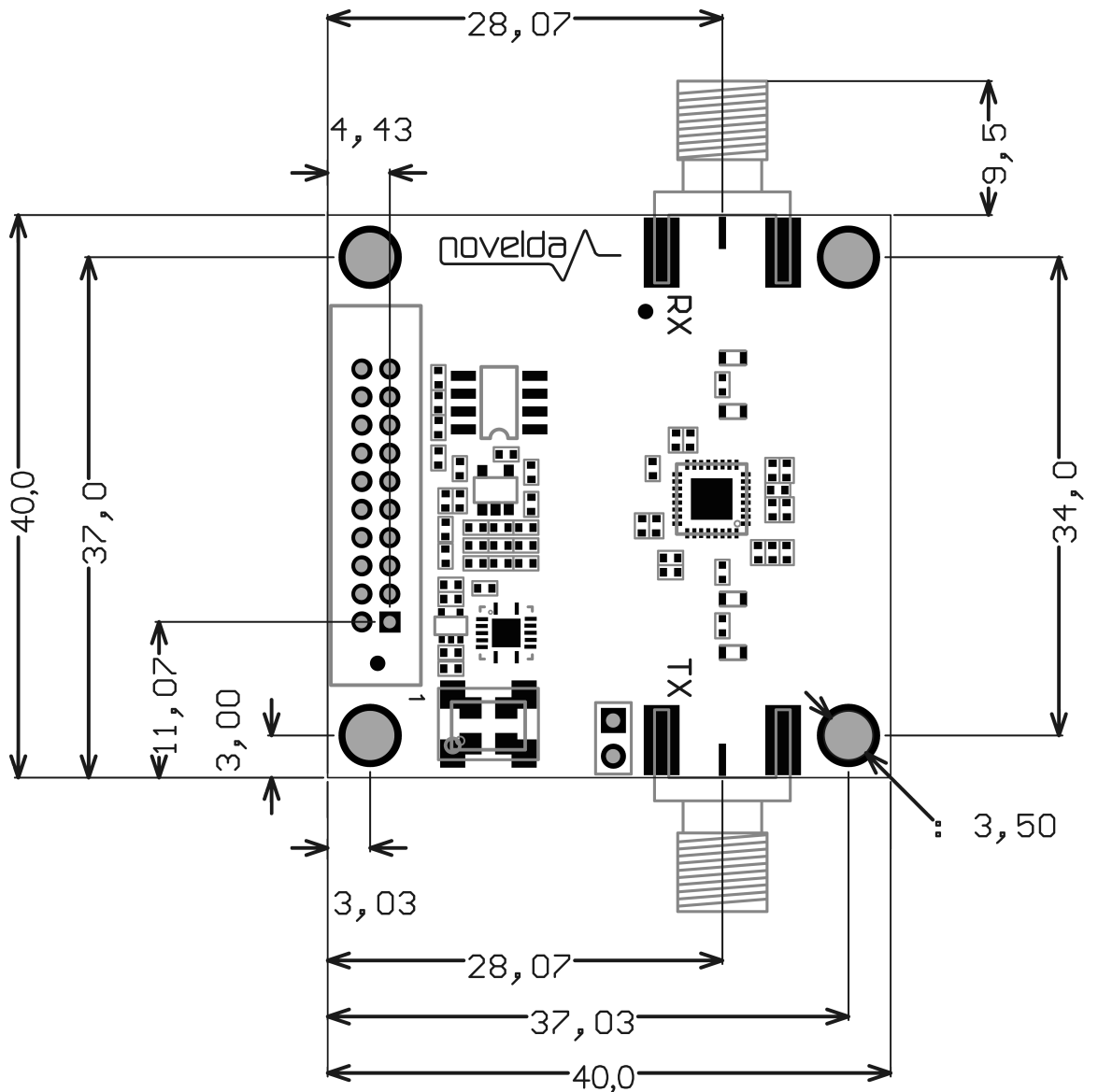

Figure 1.1. PCB dimensions

2. Circuit Description

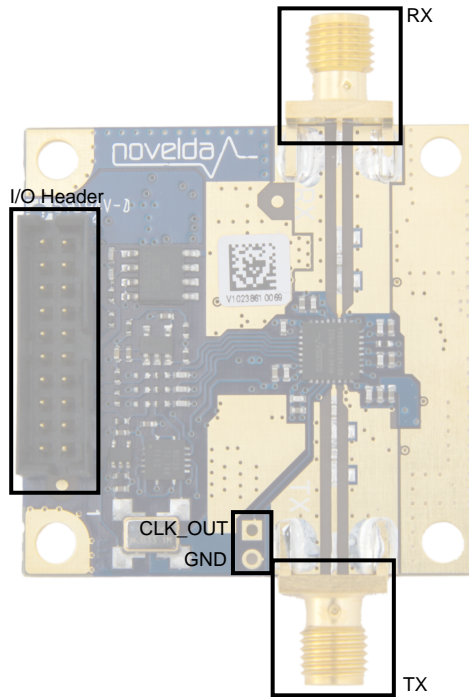

Figure 2.1. Radar Module inputs and outputs

2.1. Connectivity

2.1.1. I/O Header pinout

Figure 2.2 lists the connections of the different pins in the I/O header.

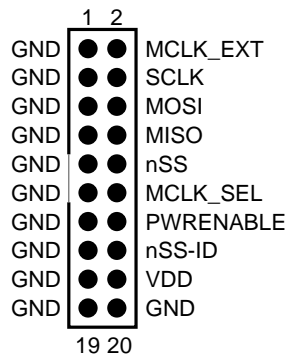

Figure 2.2. I/O Header pinout

MCLK_EXT

External clock input pin, connected to the MCLK pin on the radar IC when MCLK_SEL is low.

SCLK

SPI clock input pin.

MOSI

SPI data input pin.

MISO

SPI data output pin.

nSS
SPI slave select input pin for radar chip.

MCLK_SEL
Clock selection input pin.

PWRENABLE
Power enable input pin.

nSS-ID
SPI slave select input pin for flash.

VDD
4.5-6V DC power supply pin.

GND
Ground pin.

2.1.2. CLK_OUT Connector

The CLK_OUT connector is connected to the CLK_OUT pin of the radar IC.

2.1.3. RX and TX Connectors

There are two SMA connectors on the board, connected to the RF in (RX) and RF out (TX) ports of the radar IC. The impedance of both connectors is 50 ohm.

2.2. SPI Description

The SPI port on the NVA-R631 is used to communicate with both the NVA6100 radar IC and the AT25F512B flash IC. The nSS-ID pin selects the flash IC, and the nSS pin selects the radar IC as SPI slave. The two SPI slaves must not be selected at the same time. The block schematic of the NVA-R631 SPI subsystem is shown in Figure 2.3

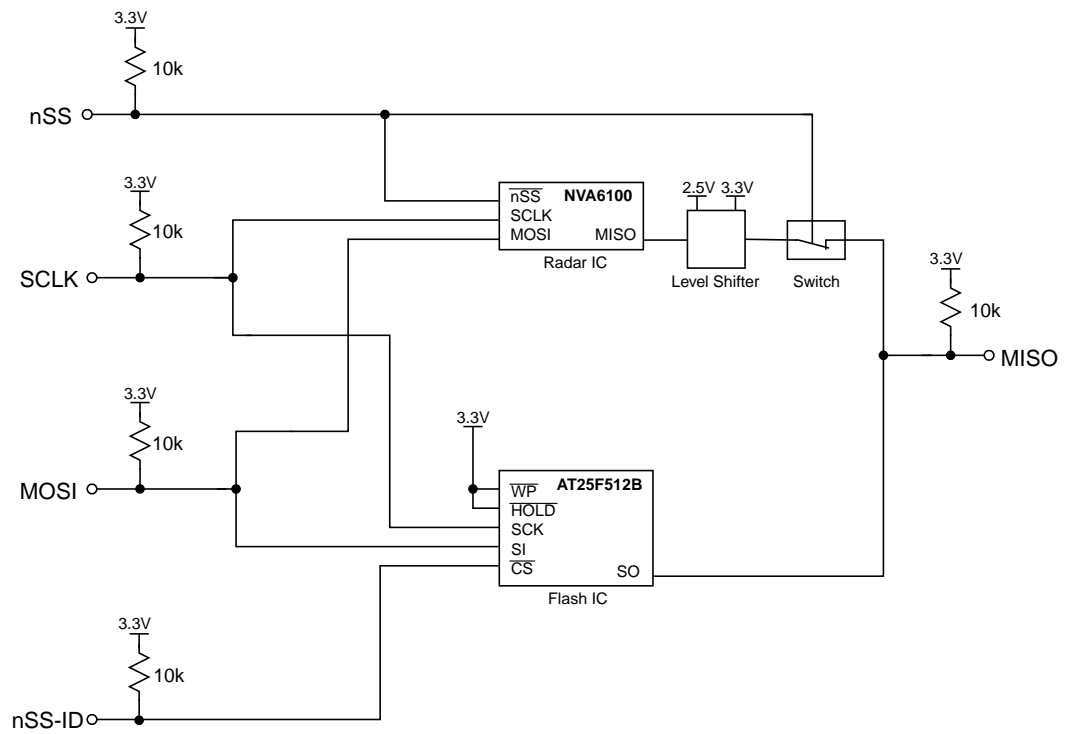

Figure 2.3. SPI subsystem block schematic

2.3. Clock Description

The NVA-R631 can be configured to use either an onboard crystal oscillator or an external clock reference as input to the NVA6100 radar IC. When the MCLK_SEL input pin is low, the crystal oscillator is enabled and connected to the radar IC. When MCLK_SEL is high, the crystal oscillator is disabled and disconnected and the MCLK_EXT pin is connected to the radar IC. The block schematic of the NVA-R631 clocking subsystem is shown in Figure 2.4

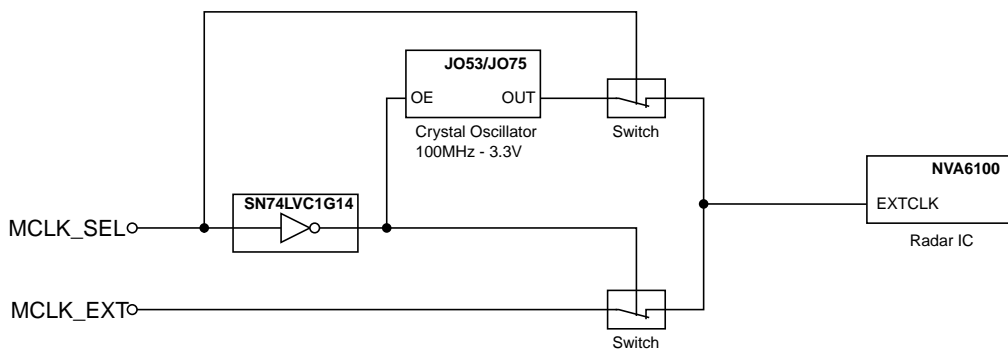

Figure 2.4. Clocking subsystem block schematic

2.4. Power Supply Description

The NVA-R631 is supplied with a 4.5-6V power supply which is regulated to 3.3V by a voltage regulator. This provides power to the flash, oscillator and switching circuitry as well as the 1.2V and 2.5V voltage regulators, supplying the NVA6100 radar IC with power.

3. Contact Information

3.1. Novelda Corporate Headquarters

Novelda AS
Garverivegen 2
NO-3850 Kviteseid
NORWAY
Phone: +47 22 49 41 19

3.2. Novelda R&D Department

Novelda AS
Gjerdrums vei 8
NO-0484 OSLO
NORWAY
Phone: +47 22 49 41 19

3.3. Ordering Information

Visit www.novelda.no or contact sales@novelda.no for information on sales and distribution.

3.4. Technical Support

For the latest update on datasheets, FAQ, application notes and errata, as well as new product releases, please visit www.novelda.no, or contact support@novelda.no.

4. Disclaimer

The information provided in this document represents Novelda's knowledge and beliefs as of the time of writing. Novelda AS reserves the right to make corrections, modifications, enhancements, improvements and other changes to its products and services at any time, and to discontinue any product or service without prior notice. Customers are encouraged to obtain the latest information before placing orders, and should verify that the information is up-to-date and complete. Information is supplied upon the condition that the persons receiving same will make their own determination as to its suitability for their purposes prior to use. In no event will Novelda be responsible for damages of any nature whatsoever resulting from the use of or reliance upon information.

All products are sold subject to Novelda's terms and conditions of sale supplied at the time of order acknowledgement. No representations or warranties, either express or implied, of merchantability, fitness for a particular purpose, that the products to which the information refers may be used without infringing the intellectual property rights of others, or of any other nature are made hereunder with respect to the information or the product to which the information refers. In no case shall the information be considered a part of our terms and conditions of sale.

Document History

Rev.	Release date	Change description
B	12-Nov-2012	Added drawing of PCB layout with dimensions.
A	03-Jul-2012	Initial release (renamed revision from 1.0 to A)